

Automation of tire classification in manufacturing

Bc. Michal Šlajs

Master's thesis
2024

 **Tomas Bata University in Zlín**
Faculty of Applied Informatics

Univerzita Tomáše Bati ve Zlíně
Fakulta aplikované informatiky
Ústav automatizace a řídicí techniky

Akademický rok: 2023/2024

ZADÁNÍ DIPLOMOVÉ PRÁCE

(projektu, uměleckého díla, uměleckého výkonu)

Jméno a příjmení: Bc. Michal Šlajs
Osobní číslo: A23543
Studijní program: N0714A150006 Automatické řízení a informatika v průmyslu 4.0
Forma studia: Kombinovaná
Téma práce: Automatizace klasifikace pneumatik ve výrobě
Téma práce anglicky: Automation of tyre classification in manufacturing

Zásady pro vypracování

1. Vypracujte literární rešerši se zaměřením na současné technologické možnosti analýzy obrazu a důrazem na X-ray zpracování.
2. Proveďte podrobnější popis možností a funkcionality současných technologií zpracování obrazu v gumárenském průmyslu zejména pro detekci vad.
3. Pracujte s dosud vyvinutou AI implementací a zvolte vhodný navazující postup a implementaci dalších naprogramovaných funkcionalit a možností ve vhodně zvoleném programovacím jazyce.
4. Popište interní AI – jeho funkcionality, celkové možnosti a porovnání s případnými ostatními dostupnými řešeními.
5. Navrhněte koncept výroby s využitím AI modelu, analyzujte přínos a možné náklady.

Forma zpracování diplomové práce: **tištěná/elektronická**

Jazyk zpracování: **Angličtina**

Seznam doporučené literatury:

1. RAUT, Roshani; KRIT, Salahddine a CHATTERJEE, Prasenjit. *Machine vision for industry 4.0: applications and case studies*. Boca Raton, Florida: CRC Press, [2022]. Dostupné z: <https://doi.org/9781000518221>.
2. *Advanced methods and deep learning in computer vision*. Computer vision and pattern recognition. London, United Kingdom: Elsevier Academic Press, [2022]. ISBN 9780128221495.
3. SZELISKI, Richard. *Computer vision: algorithms and applications*. Second edition. Texts in computer science. Cham, Switzerland: Springer, [2022]. ISBN 978-3-030-34371-2.
4. HORNBERG, Alexander. *Handbook of machine and computer vision: the guide for developers and users*. Second, revised and updated edition. Weinheim, Germany: Wiley-VCH, 2017. Dostupné z: <https://doi.org/9783527413409>.
5. ROSEBROCK, Adrian. *Deep learning for computer vision with Python*. [Místo vydání není známé]: PyImageSearch, 2017. ISBN 9781986538138.
6. GONZALEZ, Rafael C. a WOODS, Richard E. *Digital image processing*. Fourth edition. New York: Pearson, [2018]. ISBN 978-1-292-22304-9.
7. WILSON, Joseph N. a RITTER, Gerhard X. *Handbook of computer vision algorithms in image algebra*. CRC press, [2000]. ISBN 978-1-420-042382.

Vedoucí diplomové práce: **prof. Ing. Roman Šenkeřík, Ph.D.**
Ústav informatiky a umělé inteligence

Datum zadání diplomové práce: **8. prosince 2023**

Termín odevzdání diplomové práce: **27. května 2024**

doc. Ing. Jiří Vojtěšek, Ph.D. v.r.
děkan



prof. Ing. Vladimír Vašek, CSc. v.r.
ředitel ústavu

Ve Zlíně dne 8. prosince 2023

I hereby declare that:

- I understand that by submitting my Master's thesis, I agree to the publication of my work according to Law No. 111/1998, Coll., On Universities and on changes and amendments to other acts (e.g. the Universities Act), as amended by subsequent legislation, without regard to the results of the defence of the thesis.
- I understand that my Master's Thesis will be stored electronically in the university information system and be made available for on-site inspection, and that a copy of the Master's Thesis will be stored in the Reference Library of the Faculty of Applied Informatics, Tomas Bata University in Zlín, and that a copy shall be deposited with my Supervisor.
- I am aware of the fact that my Master's Thesis is fully covered by Act No. 121/2000 Coll. On Copyright, and Rights Related to Copyright, as amended by some other laws (e.g. the Copyright Act), as amended by subsequent legislation; and especially, by §35, Para. 3.
- I understand that, according to §60, Para. 1 of the Copyright Act, TBU in Zlín has the right to conclude licensing agreements relating to the use of scholastic work within the full extent of §12, Para. 4, of the Copyright Act.
- I understand that, according to §60, Para. 2, and Para. 3, of the Copyright Act, I may use my work - Master's Thesis, or grant a license for its use, only if permitted by the licensing agreement concluded between myself and Tomas Bata University in Zlín with a view to the fact that Tomas Bata University in Zlín must be compensated for any reasonable contribution to covering such expenses/costs as invested by them in the creation of the thesis (up until the full actual amount) shall also be a subject of this licensing agreement.
- I understand that, should the elaboration of the Master's Thesis include the use of software provided by Tomas Bata University in Zlín or other such entities strictly for study and research purposes (i.e. only for non-commercial use), the results of my Master's Thesis cannot be used for commercial purposes.
- I understand that, if the output of my Master's Thesis is any software product(s), this/these shall equally be considered as part of the thesis, as well as any source codes, or files from which the project is composed. Not submitting any part of this/these component(s) may be a reason for the non-defence of my thesis.

I herewith declare that:

- I have worked on my thesis alone and duly cited any literature I have used. In the case of the publication of the results of my thesis, I shall be listed as co-author.
- That the submitted version of the thesis and its electronic version uploaded to IS/STAG are both identical.

In Zlín; dated: 27.5.2024

Michal Šlajs, signed by hand
Student's Signature

ABSTRAKT

Tato diplomová práce se zaměřuje na srovnání různých systémů rentgenové inspekce, s důrazem na modely s umělou inteligencí (AI), pro inspekci pneumatik ve společnosti Continental AG. Práce zkoumá ekonomické a operativní dopady implementace plně automatizovaných systémů rentgenové inspekce a analyzuje dvě hlavní technologická řešení: interně vyvinutý AI model a software Micropoise ADR. Výsledky ukazují, že zatímco AI model vyžaduje více počátečního vývoje a integrace, nabízí větší flexibilitu a přizpůsobení pro specifické výrobní potřeby Continentalu. Na druhé straně, Micropoise ADR poskytuje robustní možnosti rozpoznání vad a je vysoce efektivní pro plně automatizační prostředí.

Klíčová slova: X-ray, rentgenové inspekční systémy, model s umělou inteligencí, In-house AI, inspekce pneumatik, Continental AG, ekonomický dopad, ADR software, automatizace ve výrobě, pneumatika.

ABSTRACT

This master's thesis focuses on comparing various X-ray inspection systems, with an emphasis on artificial intelligence (AI) models, for tire inspection at Continental AG. The work examines the economic and operational impacts of implementing fully automated X-ray inspection systems and analyzes two main technological solutions: an internally developed AI model and Micropoise ADR software. The results indicate that while the AI model requires more initial development and integration, it offers greater flexibility and customization for Continental's specific manufacturing needs. On the other hand, Micropoise ADR provides robust defect recognition capabilities and is highly effective for fully automated environments.

Keywords: X-ray, X-ray inspection systems, artificial intelligence model, In-house AI, tire inspection, Continental AG, economic impact, ADR software, automation in manufacturing, tire.

ACKNOWLEDGEMENTS

I would like to express my sincere gratitude to Dr.-Ing. René Peters for the opportunity to engage in such an interesting thesis topic under his guidance at work. I am grateful for all the valuable advice and support provided to me during working on this topic.

I would also like to thank Prof. Ing. Roman Šenkeřík, Ph.D. for his meticulous guidance and corrections of my work. Your expert comments and detailed feedback were immensely valuable and significantly contributed to achieving the higher quality of my thesis.

Your support and guidance have been crucial for my academic and personal development, and for that, I thank you both.

I hereby declare that the print version of my Master's thesis and the electronic version of my thesis deposited in the IS/STAG system are identical.

CONTENTS

INTRODUCTION	9
I THEORY	11
1 INTRODUCTION	12
1.1 INTRODUCTION OF COMPANY CONTINENTAL AG	12
1.2 TIRE COMPONENTS	12
1.3 FROM RAW MATERIALS TO X-RAY: THE TIRE PRODUCTION PROCESS AT CONTINENTAL AG	14
2 STATE OF THE ART: X-RAY MEASUREMENT IN TIRES.....	19
2.1 INTRODUCTION TO ARTIFICIAL INTELLIGENCE AND CLASSIFICATION	19
2.1.1 Definition and Basic Terms in Artificial Intelligence.....	19
2.1.2 History and Development of AI.....	22
2.1.3 Basics of classification techniques.....	23
2.2 DATA-DRIVEN TECHNIQUES AND DATASETS	27
2.2.1 The importance of data-driven approaches	27
2.2.2 Data processing and analysis techniques used in AI.....	30
2.2.3 Overview of Commonly Used Datasets and Their Role in Training AI Models.....	32
2.3 CLASSIFICATION TECHNOLOGY FOR IMAGE ANALYSIS AND QUALITY CONTROL	32
2.3.1 Classification Technologies for Image Analysis.....	32
2.3.2 Image Processing – methods and techniques:.....	35
2.3.3 Autoencoders and their Applications	37
2.3.4 PyTorch vs TensorFlow	40
2.4 X-RAY INSPECTION SOLUTIONS IN TIRES	42
2.4.1 Micropoise ADR	43
2.4.2 Yxlon.....	51
2.4.3 CyXplus.....	55
2.4.4 Other companies on the market.....	58
II ANALYSIS	59
3 AIM OF THESIS AND METHODOLOGY	60
4 IN-HOUSE AI MODEL.....	61
4.1 DESCRIPTION.....	61
4.1.1 Working with raw data.....	61
4.1.2 Preparation of data	62
4.1.3 Training on anomaly dataset	65
4.1.4 “Postprocessing”	66
4.1.5 Training and Evaluation of Autoencoders Architectures.....	69
4.1.6 Performance Evaluation of Autoencoder Architectures	69
4.1.7 Comparison of Autoencoder Architectures.....	71
4.1.8 Possibility for converting an Autoencoder into a CNN for Defect Classification.....	74
4.2 IMPROVEMENT	75
4.2.1 Current state	76

4.2.2	Enhanced approach - pixel-wise segmentation	76
4.2.3	Enhanced approach - image-processing libraries, windows size optimization.....	77
4.3	NEXT POSSIBILITIES WITH OPTIMIZATION	79
5	COMPARISON OF IN-HOUSE AI WITH EXISTING SOLUTIONS.....	81
5.1	FEATURE COMPARISON.....	81
5.1.1	Criteria for software features evaluation/capabilities.....	81
5.1.2	Benefit Comparison	84
5.1.3	Table with software solutions features in X-ray	85
5.2	CONCLUSION	87
6	DETAILED COST-BENEFIT ANALYSIS	89
6.1	ASSUMPTIONS AND FACTS (FIGURES) – COSTS.....	89
6.1.1	Common costs	89
6.1.2	Individual cost dependent on the selected system.....	90
6.1.3	Comparative Analysis:	91
6.2	IMPLEMENTATION SCENARIOS	92
6.2.1	Current X-ray situation	92
6.2.2	Fully automatic scenario from market	94
6.2.3	In-house AI scenario	97
6.2.4	Combined scenario - In-house AI + solution from market	99
6.3	COST EVALUATION.....	101
6.4	DECISION ANALYSIS	103
6.4.1	Evaluation criteria and rating - Pairwise comparison	104
6.4.2	Evaluation – criteria analysis	105
6.5	ROLL-OUT PLAN OF PROPOSED SOLUTION.....	107
7	CONCLUSION AND OUTLOOK.....	110
	LIST OF ABBREVIATIONS	115
	LIST OF FIGURES	116
	LIST OF TABLES	118
	APPENDICES.....	119

INTRODUCTION

This master thesis is dedicated to advancing the Automation of X-ray Tire Classification, a critical aspect of the Conti Tires production process that demands an efficient and precise tire classification system. The contemporary industrial landscape necessitates a robust solution capable of managing the 100% X-ray check, ensuring unwavering adherence to quality and safety standards. This master thesis undertakes a comprehensive exploration, evaluating existing technologies and proposing enhancements for an in-house AI model (Artificial Intelligence mode). Additionally, it aspires to formulate a global rollout structure based on analyses.

X-ray technology offers a detailed examination of tire internal structures, detecting concealed defects or structural issues that may compromise overall tire performance and safety. Given the automotive industry's rigorous quality standards, X-ray inspection stands as a dependable method for quality assurance. It facilitates the identification of manufacturing defects, foreign objects, or inconsistencies that might have arisen during production, acting as a preemptive measure against potential tire failures. Detecting issues early in the production process allows manufacturers to take corrective actions, minimizing the risk of product failures in the market. An example of an X-ray machine can be seen in **Figure 1**.



Figure 1: X-ray machine from company Yxlon [1]

The foundation of this thesis lies in a thorough exploration of state-of-the-art technologies, encompassing an in-depth review of X-ray measurements from major suppliers like Micropoise (*MP*)¹, Yxlon², Cyxplus³, and others. The thesis covers classification technologies, spanning from conventional methods to advanced AI models, with a specific focus on ADAMS Software, Micropoise ADR, and in-house AI software. Furthermore, the analysis extends to the X-ray technology itself, providing a holistic understanding of existing solutions.

The objective of this master thesis is to investigate the current AI model and find possible space for improvements utilized in X-ray tire classification. This involves a meticulous examination of picture segmentation techniques and a comprehensive evaluation of proposed improvements. The research employs cutting-edge methodologies, leveraging the expertise of the research team to address the intricacies of tire classification through X-ray technology. The concluding section consolidates the findings, offering a succinct summary of key improvements in X-ray tire classification. Additionally, the thesis provides insights into potential areas for future research, contributing to the ongoing advancement of X-ray tire classification systems.

¹ MicroPoise website: <https://www.micropoise.com>

² Yxlon website: <https://yxlon.comet.tech>

³ CyXplus website: <https://www.cyxplus.fr>

I. THEORY

1 INTRODUCTION

Chapter 1 provides an introduction to Continental AG, outlining its history, core areas of expertise, and a short description of the role of manufacturing steps in tire technology.

1.1 Introduction of company Continental AG

Established in 1871 in Hanover, Germany, Continental AG has grown from a modest rubber manufacturer into a prominent player in the global automotive supply and tire manufacturing industries. Today, it stands as a pillar of innovation and success, employing over 240,000 individuals worldwide. Continental is renowned for its contributions to tire technology, automotive safety systems, and other advanced automotive components, continuously pushing the boundaries of innovation and sustainability in the automotive sector. [2] [3]

1.2 Tire components

Modern passenger car tires are the product of over a century of development and innovation. Continental has been a pivotal player in the evolution of today's steel-belted radial tires, significantly enhancing tire design and functionality. Here we explore the intricate architecture of modern tires, dissecting the components from the outer layers to the core.

Structural Elements of Tires

Tire components are fundamentally categorized into two main structural elements: the tread and belt assembly, and the casing. Each of these elements comprises multiple layers that work synergistically to provide durability, stability, and performance. [4]

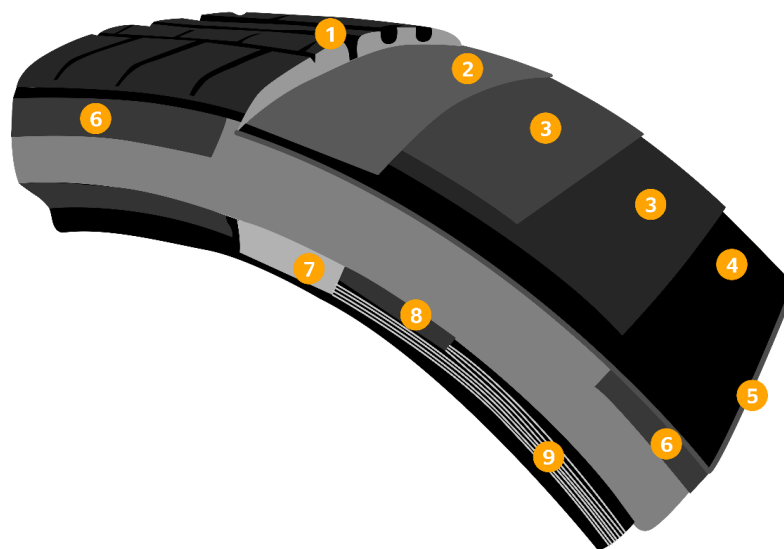

Figure 2 Tire components which are described below [4]

1. Tread:

- **Composition:** Comprised of both synthetic and natural rubber.
- **Functionality:** The tread is the tire's primary contact point with the road, designed to ensure high mileage, effective water expulsion, and secure grip under various driving conditions, thereby ensuring safety. It consists of:
 - **Cap:** Directly contacts the road, engineered for grip, wear resistance, and directional stability.
 - **Base:** Positioned beneath the cap, it reduces rolling resistance and protects the tire's internal structure or the casing.
 - **Shoulder:** Links the tread to the sidewall, facilitating a smooth transition and enhancing the tire's edge performance on roads.

Continental's Contribution: Introduced in 1904, Continental was the first to implement tread patterns, significantly enhancing road grip.

2. Jointless Cap Plies:

- **Structure:** Made from a continuous nylon cord, embedded in rubber, spirally wound from one tire side to the other without overlapping.
- **Benefits:** Allows high-speed travel and enhanced tire lifespan by preventing inter-thread friction.

Continental's Innovation: In 1923, Continental replaced the traditional woven linen fabric with a new cord fabric arrangement, which aligned cords in one direction, supported by interwoven threads. This innovation extended tire durability significantly.

3. Steel Cord Belt Plies:

- **Composition:** Comprised of robust steel cords.
- **Advantages:** Provides rigidity, enhances shape retention, improves directional stability, reduces rolling resistance, and increases mileage performance.

4. Textile Cord Ply:

- **Material:** Rubberized rayon or polyester.
- **Function:** Controls internal pressure and maintains the shape of the tire.

5. Inner Liner:

- **Material:** Airtight butyl rubber.
- **Function:** Acts like an inner tube in tubeless tires, sealing the air within and maintaining tire pressure.

6. Sidewall:

- **Material:** Primarily natural rubber.
- **Role:** Protects the casing from external damage and environmental conditions, connecting to the tread through the shoulder area.

7. Bead Reinforcement:

- **Material:** Nylon or aramid (a heat-resistant synthetic fiber).
- **Purpose:** Enhances directional stability and facilitates precise steering response.

8. Bead Apex:

- **Material:** Synthetic rubber wedge.
- **Function:** Works alongside bead reinforcement to stabilize steering and enhance driving comfort.

9. Bead Core:

- **Material:** Steel wire embedded in rubber.
- **Role:** Crucial for ensuring the tire firmly grips the wheel rim.

These components collectively contribute to the tire's performance, longevity, and safety, showcasing the intricate engineering behind modern tire manufacturing. Understanding these elements offers insights into how tires are tailored to meet diverse vehicular demands and driving conditions. [4]

1.3 From Raw Materials to X-ray: The Tire Production Process at Continental AG

Raw Material Preparation

The production of tires at Continental begins with the careful selection and preparation of raw materials, which include natural and synthetic rubber, carbon black, sulfur, and various

chemical additives. Each material plays a crucial role in defining the properties of the final tire:

- **Natural Rubber:** Harvested from the latex of rubber trees, it undergoes a series of processes including acid coagulation to separate the solid rubber, which is essential for the base structure of the tire.
- **Synthetic Rubber:** Created through the polymerization of monomers such as butadiene and styrene, synthetic rubber varieties are selected for specific characteristics like abrasion resistance and thermal stability.
- **Carbon Black:** This material, derived from the controlled combustion of petroleum products, acts as a reinforcing agent, lending strength and durability to the tire.
- **Sulfur and Vulcanizing Agents:** Vulcanization agents are critical for cross-linking rubber molecules to improve the elasticity and mechanical properties of the final product.
- **Chemical Additives:** Additives enhance the performance of the tire by improving the mixability of the compound, increasing resistance to oxidative aging, and enhancing the overall durability of the tire. [5]



Figure 3 Quality ingredients for making essential compounds [5]

Mixing Process

The initial phase in the production line involves the mixing of these raw materials. Continental utilizes advanced mixing technology to ensure that all ingredients are blended to precise specifications. This process is critical as it affects the uniformity and quality of the rubber compound, which in turn influences the performance characteristics of the tire.

- **Loading and Dosing:** Precision in the proportioning of ingredients ensures the rubber compound meets the desired chemical and physical properties.

- **Mixing and Temperature Control:** The materials are combined in large industrial mixers where temperature and mixing speed are tightly controlled to prevent premature vulcanization, which could adversely affect the material properties. [5]

Component Manufacturing

Following the mixing process, the rubber compound is fashioned into various tire components:

- **Tread and Sidewall Extrusion:** Rubber compound is extruded to form the tread and sidewall sections. The tread is responsible for road grip and wear resistance, while the sidewall contributes to the tire's structural integrity and aesthetics.
- **Cord and Fabric Layers:** Steel and textile cords are embedded within the rubber to form the carcass and belt layers, providing the tire with the necessary tensile strength and stability.
- **Bead Assembly:** Beads are produced to ensure the tire maintains a secure fit with the wheel rim, involving the precise placement of steel wires coated in rubber. [5]

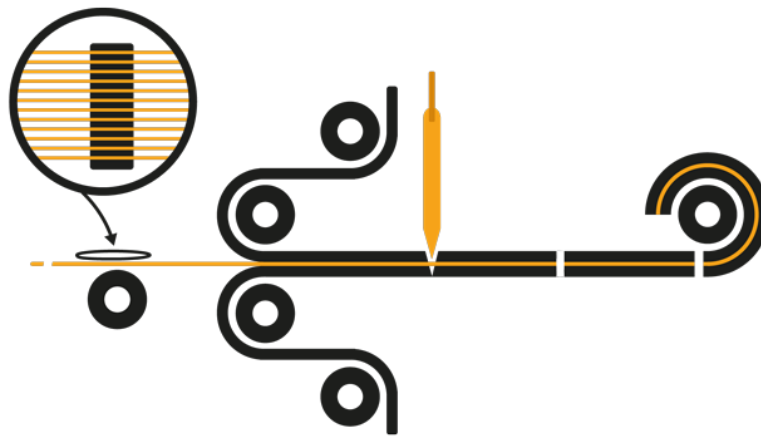

Figure 4 Manufacturing of components [5]

Assembling the tire

In the tire building phase, the various components are assembled into what is known as the "green tire." This assembly is performed on sophisticated machinery designed to precisely layer and position each component:

- **Layering:** Components like the inner liner, carcass layers, belts, and beads are meticulously assembled, ensuring each tire conforms to specific design parameters.

- **Green Tire Formation:** The assembly machine constructs the green tire by systematically adding each component, adhering to strict alignment and positioning guidelines to guarantee the tire's structural integrity and performance capabilities. [5]

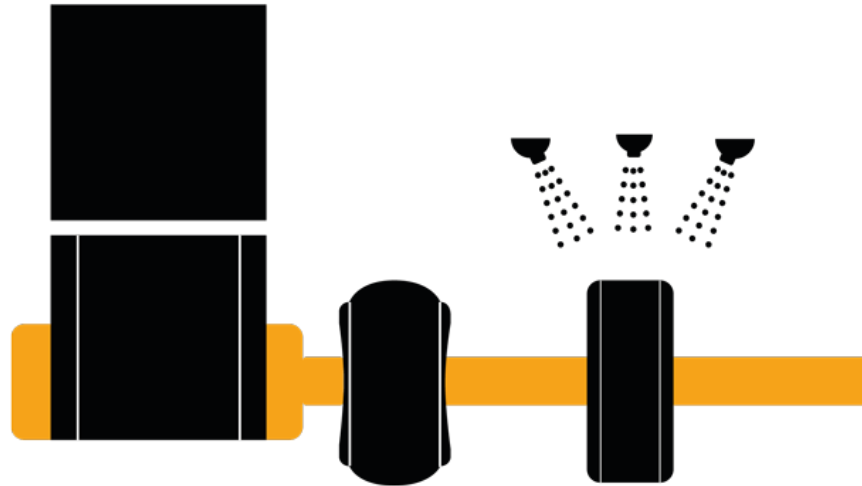

Figure 5 Building the tire [5]

Vulcanization

The green tire undergoes vulcanization, a heating process that uses sulfur to chemically bond the rubber compounds and reinforce the structure:

- **Mold and Press:** Each tire is placed in a mold that shapes the tire and imparts the tread pattern and sidewall branding during the vulcanization process.
- **Curing:** The tire is heated under controlled conditions to initiate the chemical reactions necessary for vulcanization, enhancing the material properties such as elasticity and resilience. [5]



Figure 6 Vulcanization [5]

Quality Control

Quality control is a critical aspect of the tire manufacturing process at Continental, where every stage from raw material intake to the dispatch of final products undergoes a stringent multi-level quality control process. This system ensures that all tires meet the highest standards of quality and safety.

Multi-Level Quality Control Process:

- **Visual Inspection:** After vulcanization, each tire undergoes a visual inspection where inspectors look for surface defects such as cracks, bubbles, irregularities in the tread pattern, and incorrect sidewall markings. This initial check is fundamental for identifying and eliminating apparent defects.
- **X-ray Inspection:** X-ray inspection is a key component of the quality control process, providing a detailed view of the internal structure of the tire. Specialized X-ray equipment scans the tire to detect internal defects like air pockets, insufficiently vulcanized areas, and uneven distribution of materials. This step is crucial for ensuring structural integrity and long-term functionality of the tire.
- **Uniformity Testing:** Uniformity testing assesses the tire's balance and geometric properties. Machines evaluate the weight distribution around the tire's circumference and check its dimensions and shape, which is essential for ensuring a smooth and quiet ride. Tires must pass these tests to minimize vibrations and ensure optimal interaction with the road.

Dispatch

Once the tires successfully pass all checks and inspections, they are ready for dispatch. Finished tires are packaged and sent to distribution warehouses, from where they are distributed to the sales network worldwide. Every step in the dispatch process is carefully planned and monitored to ensure that the tires reach their customers in optimal condition and on time.

This comprehensive and multi-level quality control process illustrates Continental's commitment to adhering to the highest standards of quality and safety. Innovative technologies such as X-ray inspections and thorough uniformity tests are key to maintaining customer trust and satisfaction while enabling the company to maintain its leading position in the tire market.

2 STATE OF THE ART: X-RAY MEASUREMENT IN TIRES

Detailed description and comparison of technologies and devices, their specifications, and applications in industry.

2.1 Introduction to Artificial Intelligence and Classification

2.1.1 Definition and Basic Terms in Artificial Intelligence

Artificial Intelligence (AI): Overview and Functionality AI replicates human intellectual functions through machines, particularly in computer systems. Its applications include natural language processing, machine vision, expert systems, , and speech recognition.

AI operates by processing vast amounts of data to identify patterns and correlations, which are then used to make predictions. For instance, AI can enhance chatbots for realistic conversations or improve image recognition tools. AI programming enhances cognitive abilities such as learning from data, selecting appropriate problem-solving algorithms, self-correction for accuracy, and generating creative outputs like new images or text. [6]

Classification of AI:

- **Weak AI (Narrow AI):** Engineered for specific tasks, such as industrial robots and virtual assistants like Apple's Siri. These systems are limited to specific contexts without broader cognitive capabilities.
- **Strong AI (Artificial General Intelligence, AGI):** Designed to mimic human cognitive abilities comprehensively. Strong AI can perform unprogrammed tasks using fuzzy logic to apply knowledge across various domains autonomously. Ideally, it would pass both the Turing test and the Chinese Room argument, showing human-like adaptability and understanding. [6] [7]

The Four Types of Artificial Intelligence:

- **Type 1: Reactive Machines:** These AI systems operate without memory, designed solely for specific tasks. A prominent example is IBM's Deep Blue, the chess program that won opposite Garry Kasparov in the 1990s. Deep Blue can analyze the chessboard and make strategic decisions, yet it cannot to learn from past games.
- **Type 2: Limited Memory:** These AI models possess the ability to remember past data and use it to proceed with future decisions. An example is the technology used

in autonomous vehicles that remembers encountered situations to improve driving decisions.

- **Type 3: Theory of Mind:** This category extends AI into the psychological realm, proposing systems that could understand human emotions and social interactions. Such AI would possess the social intelligence necessary to discern human intention and adapt its behavior accordingly, making it suitable for collaborative roles alongside humans.
- **Type 4: Self-awareness:** This is the most advanced form of AI, which remains theoretical at this point. These systems would have self-awareness and consciousness, recognizing their state and existence independently. Such AI would understand its capacities and self-improvement autonomously. [6]

Augmented Intelligence vs. Artificial Intelligence

"Augmented intelligence" is proposed to emphasize AI's role in enhancing human decision-making, rather than acting autonomously like the fictional examples Hal 9000 (from movie *A Space Odyssey* – year 2001) or *The Terminator* (movie from year 1984). This term helps clarify that most current AI implementations improve functionalities within specific contexts, such as business analytics or legal document review. [6]

Machine learning

Machine learning (short for ML) is a foundational approach in artificial intelligence (AI) where computers learn from data. ML algorithms identify patterns and relationships within large datasets and improve their performance on tasks over time without any other explicit programming. These algorithms use historical data to make predictions about new data. Machine learning can be sorted into two main types:

- **Supervised Learning:** The model learns from labeled data, where both the inputs and the desired outputs are provided.
- **Unsupervised Learning:** The model uses unlabeled data to identify patterns and structures on its own. [6] [7]

Neural Networks

Neural networks are a common ML technique, structured similarly to the human brain with interconnected layers of nodes, or neurons. These networks adjust connections between

neurons to recognize patterns and improve their task performance. This adaptability makes neural networks particularly effective for tasks such as image recognition, speech understanding, and language translation. [7]

Deep Learning

Deep learning, a subset of ML, utilizes deep neural networks with many layers of processing—often called hidden layers—to analyze complex data inputs. These networks are capable of discovering intricate structures in large data sets, which is why deep learning excels at challenging AI tasks like image and speech recognition, as well as natural language processing (NLP). [7]

Natural Language Processing (NLP)

NLP combines computational linguistics—rooted in ML and deep learning—with text analysis to enable computers to understand and manipulate human language. NLP technologies are behind applications such as speech recognition systems, chatbots, and automated translation services. [7]

Computer Vision

Computer vision employs ML and deep learning, particularly through convolutional neural networks, to interpret and understand visual information from the world. Applications include image and video analysis, enabling tasks such as facial recognition in security systems, object detection for autonomous vehicles, and various types of environmental perception in robotics. [7]

Advantages and Disadvantages of AI :

Advantages:

- AI excels in detail-oriented tasks like cancer diagnosis.
- It processes large data sets efficiently, useful in sectors like finance and insurance.
- AI automates tasks, enhancing productivity, such as in warehouse automation.

- It delivers consistent results in applications like translation.
- AI personalizes customer interactions, improving satisfaction.

Disadvantages:

- High implementation costs.
- Requires deep technical expertise.
- Limited availability of skilled AI professionals.
- Potential to replicate inherent biases in data.
- Difficulty in generalizing across different tasks.
- Risk of job displacement due to automation. [6]

2.1.2 History and Development of AI

Ancient and Medieval Origins: The notion of imbuing inanimate objects with intelligence dates back to ancient times. Greek mythology describes Hephaestus creating robotic servants, and in ancient Egypt, statues believed to be animated represented gods. Philosophers like Aristotle and theologians like Ramon Llull, along with later thinkers such as René Descartes and Thomas Bayes, utilized the logic of their eras to frame human cognition in symbolic terms, setting the groundwork for AI concepts like knowledge representation. [6]

Early 20th Century Foundations: The modern foundation for computers, crucial for AI, began in the 19th century with Charles Babbage and Ada Lovelace, who conceptualized programmable machines. By the 1940s, advancements like John Von Neumann's architecture for stored-program computers and the foundational theories for neural networks by Warren McCulloch and Walter Pitts were established. [6]

Mid-20th Century: The 1950s marked the formal beginning of AI as a field during a conference at Dartmouth College, led by figures like Marvin Minsky and John McCarthy, who coined the term "artificial intelligence." This era saw the development of the Turing Test by Alan Turing and early AI programs like the Logic Theorist by Newell and Simon. [6]

Late 20th Century Growth and Stagnation: Despite early optimism, achieving artificial general intelligence proved challenging, leading to periods of reduced interest and funding

known as "AI Winters" in the 1970s and 1980s. However, the 1990s witnessed a resurgence in AI, propelled by increased computational power and significant data availability, exemplified by IBM's Deep Blue defeating chess champion Garry Kasparov. [6]

21st Century Advances: The 2000s and 2010s saw rapid advancements in AI, driven by improvements in machine learning, deep learning, and natural language processing. Notable developments included Google's search algorithms, Amazon's recommendation systems, and breakthroughs in voice recognition and autonomous vehicles. The decade culminated with achievements like IBM Watson winning Jeopardy and Google DeepMind's AlphaGo defeating the world Go champion. [6]

Current Decade: The 2020s are defined by the rise of generative AI, which creates new content from various prompts.

2.1.3 Basics of classification techniques

Classification is a core task in natural language processing. It relies on machine learning algorithms to categorize data. This task varies widely, with sentiment analysis being one of the most commonly implemented forms. Each classification problem may require a distinct algorithm tailored to its specific demands. [8]

Classification involves identifying and categorizing data into predefined groups or classes based on their features. Machine learning models are trained on datasets where the categories are known (labeled data) to learn how to classify new, unseen datasets accurately. Common applications of classification include filtering emails and analyzing sentiment in text. [8]

Selecting the Suitable Algorithm

As noted by computer scientist David Wolpert, selecting the appropriate algorithm is crucial and depends on the specific problem, available computational resources, and the method for estimating and comparing algorithm performance. This often involves experimenting with various algorithms and configurations to determine the most effective approach. [8]

Key Classification Algorithms:

1) Logistic Regression

Logistic regression is employed to forecast binary outcomes, such as Yes/No, Pass/Fail, or Alive/Dead. This method analyzes independent variables to predict a binary outcome, categorizing results into one of two possible states. These variables may be either categorical or numerical, but the outcome variable is always categorical. [8]

The formula (1) for logistic regression is represented as:

$$P(Y = 1|X) \text{ or } P(Y = 0|X) \tag{1}$$

which calculates the probability of the outcome variable Y given the predictors X .

For instance, logistic regression might be used to determine the sentiment of a word, assessing whether it carries a positive or negative meaning, or to identify objects in images, assigning a probability to each potential category such as tree, flower, or grass. [8]

2) Naive Bayes

The Naive Bayes algorithm estimates whether a data point likely belongs to a particular category or not. This technique is particularly useful in text analysis for classifying words or phrases into specific categories. [8]

To use Naive Bayes for determining a category, you would calculate the conditional probabilities associated with each category. For example, to decide whether a phrase pertains to "sports," the formula used involves the likelihood of the phrase given the category 'sports,' multiplied by the probability of observing the category 'sports,' all divided by the likelihood of the phrase. This formula helps in assessing the probability of different categories given the data. [8]

These rephrased descriptions provide a clearer understanding of how logistic regression and Naive Bayes are applied in predicting and categorizing data, which should fit well into an academic context. [8]

Text	Tag
"A great game"	Sports
"The election was over"	Not sports
"Very clean match"	Sports
"A clean but forgettable game"	Sports
"It was a close election"	Not sports

Figure 7 Example of Naive Bayes [8]

3) K-Nearest Neighbors (k-NN):

The K-Nearest Neighbors (k-NN) algorithm is a widely used method for pattern recognition that classifies data points based on the closest examples in the training dataset. This method operates by identifying the 'k' instances that are nearest to an unknown data point and assigns it to the category most common among these neighbors. [8]

Functionality of operation in k-NN:

In the application of k-NN to classification tasks, the algorithm assigns a data point to the class of its nearest neighbors based on a simple majority vote. For example, if 'k' is set to 1, the data point is classified directly into the category of its single nearest neighbor. The number 'k' is a user-defined parameter and plays a crucial role in the classification accuracy of the algorithm, affecting how closely the nearest neighbors reflect the classification of the new example. [8]

4) Decision Trees:

Decision trees are a type of supervised learning algorithm. Ideally they are suited for addressing classification challenges. They function analogously to a flow chart, methodically dividing data points into increasingly specific categories, beginning broadly at the "tree trunk" and branching out into finer subdivisions. [8]

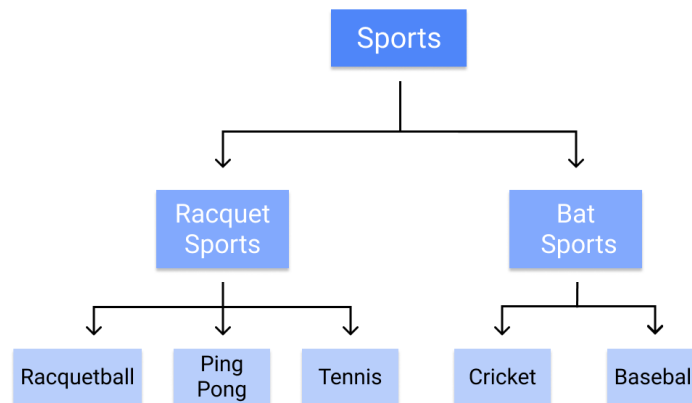
Functionality of Decision Trees:**Figure 8** Decision tree example [8]

In operation, decision trees segregate datasets step-by-step into two closely related groups. This bifurcation continues from the trunk through the branches and further into the leaves of the tree, where each leaf represents a highly specific category. This hierarchical structure facilitates nuanced differentiation within the data, enabling precise classification levels with minimal need for human intervention. [8]

Random Forest

In practice, the random forest algorithm does not simply use a single tree but averages the predictions of all the trees it has created. This averaging process helps align the new data points to the most appropriate tree within this ensemble, effectively determining the data's classification. One of the major strengths of random forests is their capacity to prevent overfitting—a common limitation in single decision trees—where data points might be forced into overly specific categories. By utilizing a collective decision-making process across various trees, random forests ensure a more generalized and robust classification. [8]

5) Support Vector Machines (SVM):

The Support Vector Machine (short for SVM) algorithm is a sophisticated tool in machine learning that leverages complex algorithms to facilitate the training and classification of data points across multiple dimensions. Unlike simple X/Y prediction models, SVM operates within a multidimensional space, allowing for more nuanced classification. [8]

Mechanism and Functionality of SVM:

To illustrate its functionality, consider a scenario where data points are represented by two distinct tags: red and blue, based on two features, X and Y. Through training, the SVM algorithm learns to categorize these data points into their respective tags by determining an optimal hyperplane that effectively separates them. In a two-dimensional space, this hyperplane corresponds to a line, with data points falling on either side being classified as red or blue. [8]

Complexity and Accuracy:

As data sets grow more complex, a single linear hyperplane may not be sufficient for accurate classification. In such cases, SVM adapts by extending its capabilities into higher dimensions, allowing for the creation of curved or nonlinear hyperplanes. This increased dimensionality enables SVM to accurately classify data points even in scenarios where a linear separation is not feasible. [8]

Applications of Classification:

- **Sentiment Analysis:** Determining the emotional tone behind a body of text.
- **Email Spam Detection:** Filtering out spam emails based on their content.
- **Document Classification:** Organizing documents into categories automatically.
- **Image Classification:** Assigning categories to images based on their content.

Understanding and applying the right classification algorithms can significantly help enhance the accuracy and efficiency of machine learning tasks, driving advancements in numerous AI applications. [8]

2.2 Data-Driven Techniques and Datasets

2.2.1 The importance of data-driven approaches

Data-centric approaches in artificial intelligence (AI) involve creating AI models that utilize extensive data sets to make predictions, decisions, or suggestions. In contrast to traditional systems that rely on explicitly programmed rules, data-driven AI models harness data to

uncover patterns, connections, and behaviors. This method is gaining traction because of its proficiency in managing intricate and evolving data scenarios. [9]

Core Concepts of Data-Driven AI

Is fundamentally about learning from data. It involves training models using vast datasets to recognize and generalize patterns without human intervention. This process allows AI systems to adapt to new information and also really much improve over time. The techniques underpinning data-driven AI include parts as neural networks, machine learning and deep learning, all of which rely heavily on data to function effectively. For instance, recommendation engines such as those used by Netflix analyze users' viewing habits along with the habits of millions of other users to suggest content. These engines process enormous datasets to tailor recommendations to individual preferences, enhancing user experience significantly. [9]

Risks and Mitigations

While data-driven AI offers numerous advantages, it also presents several risks. Privacy concerns are paramount, particularly as AI systems often require access to sensitive personal data. Ensuring transparency and implementing robust privacy measures are essential to mitigate these risks. Data quality is another critical issue. AI models trained on biased or incomplete data can perpetuate these biases or produce inaccurate results. Regular auditing and ensuring the diversity and representativeness of training data are crucial steps to address this problem. Moreover, ethical considerations are increasingly important as AI systems can significantly impact areas like hiring processes and medical diagnoses. It is crucial to guarantee fairness and accountability in AI decision-making to avoid negative consequences. [9]

Examples of Data-Driven AI

Data-driven AI is pervasive across various industries. In healthcare, AI enhances disease diagnosis and drug discovery by analyzing medical data. In finance, algorithms assess stock market trends to provide trading insights. Agriculture benefits from AI through precision farming, which optimizes crop yields based on soil, weather and all kind of historical data.

A widely recognized example is voice recognition technology. Assistants like Alexa and Siri continuously analyze user interactions to improve their understanding and responsiveness, demonstrating the adaptive capabilities of data-driven AI. [9]

Model-Driven AI vs. Data-Driven AI

Relies on rules which are predefined and human-crafted models, which encode specific knowledge needed for tasks. These systems do not require large datasets to function and are typically less adaptable than data-driven models. Traditional expert systems in finance, which follow set rules for decision-making, are an example of model-driven AI. The choice between model-driven and data-driven AI really depends on the data availability itself and also on use case. Data-driven AI excels when sample data is available to uncover complex patterns, whereas model-driven AI is suitable for tasks requiring specific, well-defined rules. [9]

Advantages:

- **Unparalleled Insights:** Data-driven AI can analyze extensive datasets to uncover trends and patterns beyond human capability, providing valuable insights into customer behavior and market dynamics.
- **Personalization:** AI can tailor recommendations and content to individual users, significantly enhancing user experience in e-commerce, entertainment, and content delivery.
- **Scalability:** These models can scale with increasing data volumes, continuously learning and adapting to new information.
- **Real-Time Decision Making:** Systems with AI can make immediate decisions based on live data streams, which is crucial in applications like fraud detection and autonomous vehicles.
- **Consistency:** AI models perform repetitive tasks consistently without fatigue, ensuring precision and reliability. [9]

Disadvantages :

- **Data Quality Dependency:** The effectiveness of AI models is highly dependent on the quality of the training data. Poor data can lead to flawed outcomes.

- **Privacy Concerns:** The extensive use of personal data raises significant privacy issues. Balancing data utility and privacy is essential.
- **Ethical Issues:** It can perpetuate biases present in training data, raising ethical concerns. Addressing these biases is critical.
- **Black Box Problem:** Many AI models operate as "black boxes," making their decision-making processes opaque and difficult to understand.
- **Data Quantity and Cost:** Training data-driven AI models requires massive datasets, which can be expensive and time-consuming to acquire and process.
- **Human Oversight:** AI systems often require human oversight for tasks like data cleaning and model validation, which adds to the labor costs. [9]

Data-driven AI has transformative potential across various industries, offering unprecedented insights and capabilities. However, the challenges it presents, such as privacy concerns, data quality, and ethical considerations, must be carefully managed. Responsible and ethical development is crucial, ensuring that privacy is protected, data quality is kept in loop, and biases are actively listed. As we continue to harness the power of data-driven AI, striking a balance between its immense potential and ethical responsibilities will be increasingly important. [9]

2.2.2 Data processing and analysis techniques used in AI

Data analysis is a critical component of decision-making processes across various industries. With the advent of artificial intelligence (AI), the techniques used for data analysis have become more sophisticated, enabling the extraction of valuable insights from both structured and unstructured data. This chapter delves into the methods and tools employed in AI for data analysis, illustrating how these technologies enhance data processing and decision-making. [10]

1. Data Collection

The initial step in any data analysis process is data collection. This involves gathering datasets from reliable sources based on the specific objectives of the analysis. In an AI context, the data collected can come from a multitude of sources, including databases, sensors, social media, and other digital platforms. The quality and relevance of the data collected are paramount as they significantly impact the outcomes of the analysis. [10]

2. Data Cleaning

Once data is collected, the next crucial step is data cleaning. This process involves identifying and correcting errors, removing irrelevant information, and dealing with missing values. AI can significantly streamline data cleaning by using machine learning algorithms to detect anomalies and inconsistencies within large datasets. This automation not only saves time but also enhances the accuracy of the data used for further analysis. [10]

3. Data Analysis

Data analysis encompasses inspecting, cleaning, and modeling data to extract meaningful insights. AI employs several advanced techniques in this phase, including: [10]

4. Data Interpretation

After analyzing the data, the next step is to interpret the results. This involves understanding the trends and patterns identified during the analysis phase and making informed decisions based on these insights. AI enhances data interpretation by providing predictive analytics and visualization tools that help stakeholders grasp complex data trends quickly and accurately. [10]

Applications of AI in Data Analysis

AI-powered data analysis is transforming various sectors by providing deeper insights and enabling more informed decision-making. Some notable applications include:

- **Sentiment Analysis** - AI systems analyze online content to gauge public sentiment toward a brand or product. For example, Netflix uses AI to analyze viewer feedback and improve user experience by addressing identified pain points.
- **Predictive Analytics and Forecasting** - AI can predict future trends based on historical data. Financial institutions, like Bank of America, use predictive analytics to understand market trends and make investment decisions.
- **Anomaly Detection and Fraud Prevention** - AI systems can detect unusual patterns in data that may indicate fraudulent activities. Spotify, for example, employs AI to identify and mitigate fraudulent streaming behavior.
- **Image and Video Analysis** - AI's ability to analyze visual data has applications in various fields, from healthcare (e.g., diagnosing diseases through medical imaging) to retail (e.g., managing inventory). [10]

AI has revolutionized data analysis by automating complex processes, enhancing accuracy, and providing deeper insights. As AI technologies continue to advance, their applications in data analysis will expand, offering even greater capabilities and transforming how businesses and organizations make data-driven decisions. [10]

2.2.3 Overview of Commonly Used Datasets and Their Role in Training AI Models

In the realm of AI, various datasets serve as foundational tools for training and evaluating models. These datasets are critical for developing algorithms capable of performing specific tasks accurately. Below are some of the most used datasets in AI and their significance: [11]

ImageNet

ImageNet is one of the largest visual databases designed for visual object recognition research. It contains millions of images labeled with descriptive tags. This dataset is pivotal in training models for object detection, image classification and segmentation tasks. The annual ImageNet Large Scale Visual Recognition Challenge (short for ILSVRC) has driven significant advancements in deep learning and computer vision. [11]

MNIST

The MNIST (Modified National Institute of Standards and Technology) dataset consists of a large collection of handwritten digits. It includes about 60,000 training images and 10,000 testing images, each representing digits from 0 to 9. MNIST is widely used for benchmarking and evaluating image processing algorithms, especially in the initial phases of research and development. [11]

2.3 Classification technology for image analysis and quality control

2.3.1 Classification Technologies for Image Analysis

Image classification in the field of computer vision is pivotal for a wide array of applications, from medical diagnostics to autonomous driving. This chapter delves into machine learning techniques for image classification, with a particular focus on Convolutional Neural Networks (CNNs), as well as supervised and unsupervised classification methods. [12]

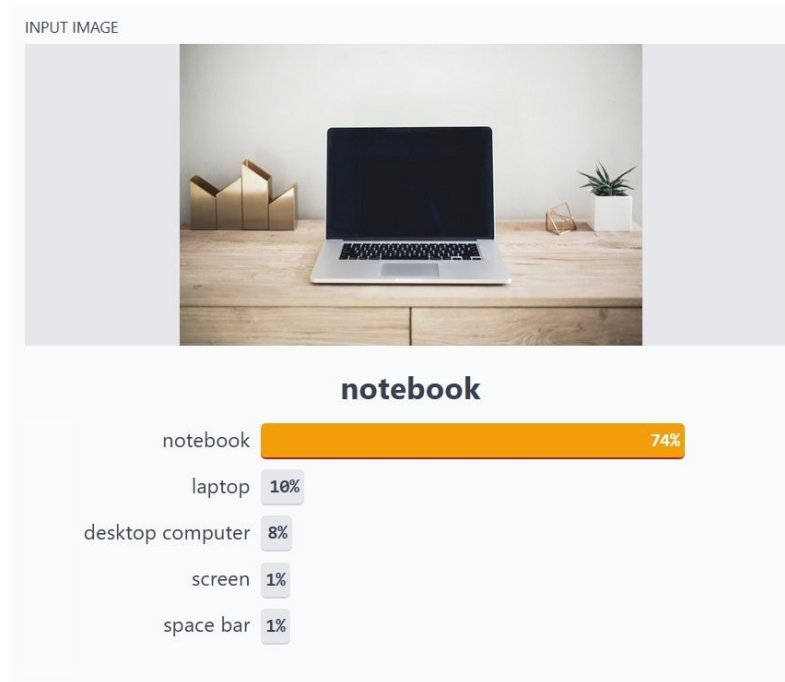

Figure 9 Image classification: The deep learning model returns classes along with the detection probability (confidence) [12]

1) Convolutional Neural Networks (CNNs) in Deep Learning:

CNN Architecture and Functionality:

CNNs are specialized kinds of neural networks for processing data that have a grid-like topology as images have. An image is treated as an input matrix, and various filters are applied to create feature maps that abstract higher-level features:

- **Convolutional Layer:** Extracts features by applying filters that capture spatial hierarchies between pixels.
- **Activation Layer (ReLU):** Introduces non-linear properties to the system, helping the network to learn complex patterns.
- **Pooling Layer:** Reduces dimensionality and computational complexity; provides translation invariance.
- **Fully Connected Layer:** Each neuron receives input from all neurons in the previous layer, integrating features globally.
- **Output Layer:** Produces the classification output based on the features recognized by the network. [12]

Training CNNs

Training involves optimizing the filter weights to minimize the prediction error, typically using backpropagation and a large number of labeled training examples.

Convolutional Neural Network

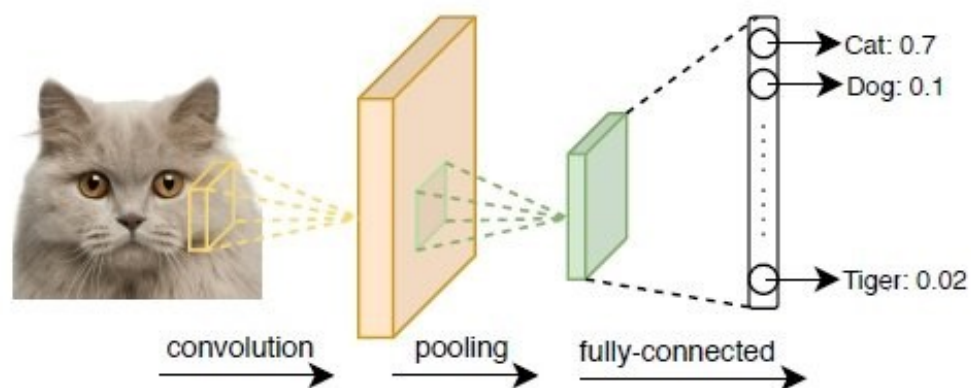

Figure 10 Concept of Convolutional Neural Networks (CNNs) [12]

2) Supervised Image Classification

Techniques in Supervised Classification:

- **Maximum Likelihood Classification (MLC):** This method assumes a normal distribution for class features, estimating the likelihood of each pixel's classification into predefined categories using statistical metrics such as mean and variance.
- **Minimum Distance Classification:** Classifies pixels based on the proximity of their feature set to the mean feature set of pre-defined classes.

Advantages and Limitations

Supervised classification typically achieves high levels of accuracy; however, its success is heavily dependent on the quality of the training data. Performance can substantially decline with poorly labeled data or inadequate sample sizes. [12]

3) Unsupervised Image Classification

Common Algorithms:

- **K-means Clustering:** Partitions pixels into K clusters by minimizing intra-cluster variance. It's widely used for its simplicity and effectiveness.
- **ISODATA Algorithm:** Allows for dynamic cluster adjustment, which can merge or split clusters based on the dataset's complexity. [12]

Applications and Challenges:

Unsupervised classification is ideal for exploring data structures when labels are not available. However, the success largely depends on choosing suitable features and the number of clusters, which can sometimes be subjective. [12]

4) Comparing Supervised and Unsupervised Classification

Supervised methods are preferable for tasks with available annotated data, offering precision and learning from previous annotations. Unsupervised methods, however, are valuable in scenarios where such data is unavailable, providing initial insights and pattern recognitions that can be crucial for further analysis or subsequent supervised learning. [12]

Recent advancements include deep learning architectures like ResNet and Inception, which provide refined frameworks for handling more complex image classification tasks with better accuracy and efficiency. [12]

Image classification technologies have evolved significantly, driven by both theoretical advancements in machine learning and practical applications that demand increasingly sophisticated tools. The choice of classification technique—whether a deep learning approach like CNNs or traditional methods like MLC — which depends on the characteristic requirements and constraints of the task at hand. [12]

2.3.2 Image Processing – methods and techniques:

In the digital era, images play a pivotal role across diverse fields, including social media and medical diagnostics. The field of computer vision is dedicated to deriving significant

information from images. Image processing, an essential aspect of computer vision, entails the manipulation and analysis of images to improve their quality, identify important elements, and facilitate automated interpretation. [13]

1) Importance of Image Processing

Images are rich sources of data across multiple applications. Image processing allows us to derive meaningful information from images and videos, which is crucial for enhancing computer vision capabilities.

- **Enhancement and Restoration – Techniques** in image processing improve image quality by removing noise and enhancing visual clarity, particularly in challenging conditions like low light or high noise environments. Restoration methods enhance interpretability by reducing noise and clarifying details.
- **Feature Extraction and Object Recognition** – Detecting and identifying patterns and specific objects within images is a common application in computer vision. Techniques in image processing enable the extraction of important features, such as edges and textures, which are critical for subsequent object recognition tasks, allowing machines to recognize and classify objects accurately.
- **Image Segmentation** – This technique divides images into segments based on visual characteristics, separating foreground from background, which is essential for applications such as object tracking, medical imaging, and autonomous navigation. Segmentation allows for focused analysis on particular regions within of image.
- **Classification and Pattern Recognition** – Image processing is fundamental to classification and pattern recognition, enabling algorithms to analyze images' statistical characteristics and visual patterns to distinguish between various classes or categories, such as different objects, scenes, or emotional expressions.
- **Medical Imaging and Diagnosis** – In healthcare, image processing is crucial for diagnosing diseases, allowing for the detection of abnormalities and monitoring treatment progression through techniques like segmentation and feature extraction, thereby aiding in precise diagnoses and less invasive treatments. [13]

2) Common Image Processing Techniques:

These techniques are vital for achieving the objectives outlined above. Here are some fundamental methods:

- **Filtering and Convolution** - These techniques enhance image quality by applying filters that alter characteristics such as blur, sharpness, and noise. Convolution involves sliding a filter over the image and applying mathematical operations to each pixel to modify these attributes.
- **Histogram Equalization** - This technique boosts the contrast of images by modifying the distribution of pixel intensities. It is particularly useful for enhancing details in images that are underexposed or lack contrast.
- **Edge Detection** - Tools like the Canny edge detector and Sobel operator are used to detect significant changes in image brightness, which help in outlining boundaries and important features. These are crucial for tasks like object detection, shape analysis, and feature extraction.
- **Image Transformation** - Methods that change the geometry of images, such as rotation, scaling, and translation, help in aligning images, correcting perspectives, and modifying spatial relationships to improve analysis and interpretation.
- **Feature Detection and Extraction** - This involves pinpointing and pulling out specific visual patterns or structures, such as corners, edges, or textures. These are represented numerically and are vital for enhancing technologies in image fusion, object recognition, and localization.
- **Advanced Segmentation** - Segmenting an image into distinct regions based on visual properties allows for the isolation of important areas for more detailed analysis. This segmentation can be achieved through methods like thresholding, clustering, and graph-based algorithms, which support tasks such as object detection and gaining semantic insight.
- **Object Detection and Recognition** - This process involves spotting and categorizing objects or patterns in images through machine learning models trained to recognize specific visual features. Advances in deep learning, particularly with Convolutional Neural Networks (CNNs), have greatly enhanced the effectiveness and accuracy of object detection in various fields. [13]

2.3.3 Autoencoders and their Applications

Autoencoders are a class of artificial neural networks employed to learn efficient encodings of data in an unsupervised manner. They are fundamentally used for tasks like

dimensionality reduction and feature learning but have expanded into a variety of applications across fields. [14]

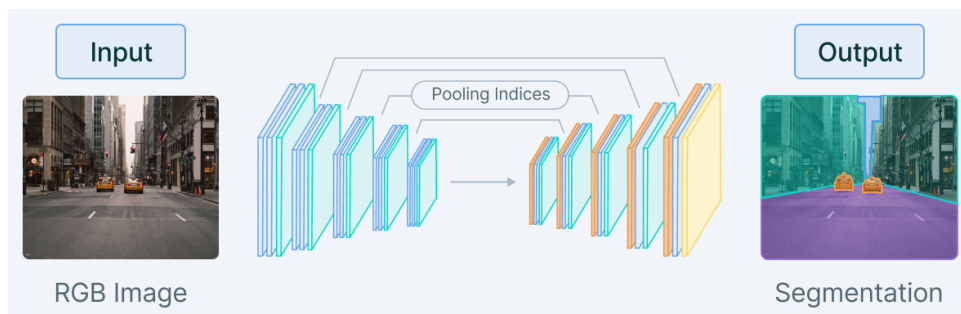

Figure 11 Convolutional encoder-decoder [14]

Understanding Autoencoders:

An autoencoder's primary function is to learn a compressed, encoded representation of data. It consists of these main parts:

- **Encoder:** This component compresses the input data into a smaller encoded representation.
- **Bottleneck:** This is the layer that contains the compressed knowledge of the input data.
- **Decoder:** This part reconstructs the input data from the compressed code to be as close as possible to the original input. [14]

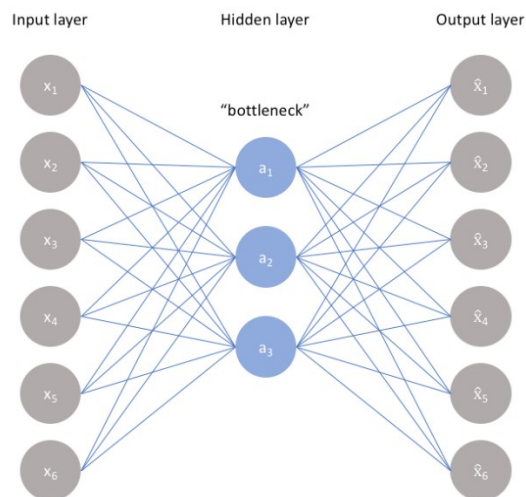

Figure 12 Architecture of Autoencoders [14]

Training Autoencoders:

- **Setting Hyperparameters:** This involves selecting parameters such as the size of the bottleneck (code size), the number of layers in the network, and the number of nodes within each layer to optimize model performance.
- **Loss Functions:** Typical loss functions used in these models include Mean Squared Error (MSE) for continuous data, and Binary Cross-Entropy for binary data, to quantify the difference between the predicted and actual outputs.
- **Backpropagation:** This technique is utilized to reduce the loss function by adjusting the network's weights, aiming to improve the model's ability to reconstruct the input data accurately.

Types of Autoencoders:

- **Undercomplete Autoencoders:** Focus on learning a compressed representation of the input, mainly used for dimensionality reduction.
- **Sparse Autoencoders:** Utilize regularization techniques to impose sparsity on the hidden layers, enhancing feature selection.
- **Contractive Autoencoders:** Introduce a regularization term that encourages the model to be insensitive to slight variations in input data.
- **Denoising Autoencoders:** Aim to reconstruct a clean input from a corrupted version, effectively learning to ignore the "noise" in the inputs.
- **Variational Autoencoders (VAEs):** Learn a probabilistic latent space of the inputs, which allows them to generate new instances that are similar to the input data. [14]

Applications of Autoencoders:

- **Dimensionality Reduction:** Autoencoders can reduce data dimensions without losing critical information, aiding in tasks like data visualization and compression.
- **Image Denoising:** They are effective in removing noise from images, surpassing traditional methods by learning optimal filters.
- **Generative Models:** Variational autoencoders can generate new data points with similar properties as the input data, useful in domains like synthetic data generation.
- **Anomaly Detection:** Autoencoders can be trained to reconstruct normal data efficiently; hence, anomalies can be detected through poor reconstruction. [14]

Autoencoders serve as powerful tools for understanding and compressing data in an unsupervised manner. While the concept may seem straightforward, the practical applications and the depth of learning the models can achieve are profound. These networks not only enhance our ability to process large volumes of data but also open avenues for innovative applications across various industries. [14]

2.3.4 PyTorch vs TensorFlow

In the rapidly evolving field of deep learning, selecting the right framework is crucial for both academic research and industrial applications. PyTorch and TensorFlow are two of the leading libraries that have dominated this space, each with its own strengths and user base. [15]

Overview of PyTorch and TensorFlow:

- **PyTorch:** Developed by Facebook's AI Research lab, famous for its ease of use, flexibility, and dynamic computation graph. It allows for on-the-fly adjustments during model training, which is particularly valuable for research and development.
- **TensorFlow:** Created by Google. Is known for its robust scalability and comprehensive ecosystem supporting large-scale deployment and production. It employs a static computation graph that optimizes the computational efficiency of large models. [15]

Ease of Learning and Use:

- PyTorch is often praised for its straightforward, "Pythonic" interface, making it an ideal choice for beginners and researchers focused on innovation and fast prototyping.
- TensorFlow, while offering a steep learning curve, provides a structured environment that is highly optimized for performance and large-scale model training. TensorFlow 2.0 has introduced Eager Execution to incorporate more dynamic graph capabilities, somewhat narrowing the usability gap between itself and PyTorch. [15]

Performance and Scalability

- TensorFlow excels in handling distributed training and massive datasets, making it suitable for enterprise-level applications where performance and scalability are critical.
- PyTorch has been making significant strides in enhancing its capabilities for distributed training and scalability, with updates that support multi-GPU and multi-machine training environments. [15]

Community and Support

- TensorFlow has a more established community given its longer presence in the industry. It boasts extensive resources such as tutorials, courses, and community support that can be invaluable for solving complex issues.
- PyTorch has seen rapid growth in its community, especially among researchers and academics, due to its user-friendly nature and adaptability in experimental settings. [15]

Flexibility and Innovation

- PyTorch offers greater flexibility due to its dynamic computation graph, facilitating more innovative and complex model architectures. This has made it particularly popular in academic research where experimentation is more frequent.
- TensorFlow has been traditionally less flexible, but ongoing updates aim to enhance its capability for innovation, striving to balance its robustness with versatility. [15]

Industry Adoption

- TensorFlow is widely used in industry and is known for its robustness, making it a preferred choice for large-scale applications in production environments.
- PyTorch is gaining traction rapidly, not only in the academic sphere but also among industry practitioners, driven by its ease of use and flexible nature. The release of production-grade features and models like ChatGPT has further solidified its position. [15]

1) TensorFlow Applications:

- Google Search and Recommendations: Enhancing search algorithms and personalizing user recommendations.
- NVIDIA Deep Learning Accelerator (NVDLA): Optimizing deep learning applications on NVIDIA's hardware accelerators.
- Uber's Michelangelo: Supporting machine learning pipelines for predictions, fraud detection, and pricing. [15]

2) PyTorch Applications:

- Facebook: Various AI-driven features like content recommendation and language translation.
- Tesla Autopilot: Core deep learning tasks such as object detection for autonomous driving.
- OpenAI GPT Models: Natural language processing tasks including text generation and language translation. [15]

The choice between PyTorch and TensorFlow largely depends on specific project needs, preferences for ease of use versus scalability, and whether the deployment environment favors experimentation or robust deployment. Both frameworks continue to evolve, with each new update potentially shifting the balance in their ongoing rivalry. The decision on which framework to adopt should be guided by the specific requirements and context of the intended application, rather than a one-size-fits-all approach. [15]

2.4 X-ray inspection solutions in Tires

In this chapter, we will explore the advanced X-ray inspection technologies that are crucial for ensuring quality in the manufacturing of tires. These systems provide detailed insights into the internal structure of tires, enhancing defect detection and improving overall product reliability. We will discuss various specialized machines and software developed by leading companies in the field, highlighting their unique features and the significant benefits they bring to tire manufacturing processes.

2.4.1 Micropoise ADR

2.4.1.1 *Machine from Micropoise*

The CTXS Plus is an X-ray inspection system specifically engineered to address quality control in the manufacturing of Passenger Car Radial (PCR) and Truck and Bus Radial (TBR) tires. So Micropoise is strongly focusing on both parts of tires – PCR and TBR which is not 100% common. What can be highlighted is also the robotic tire handling mechanism which distinguishes it from conventional systems typically used at Continental and other similar environments. [16]

Multi-axis Robot Tire Handling

Unlike traditional tire X-ray inspection systems, the CTXS Plus integrates a multi-axis robot for tire handling. This robotic system precisely manipulates and positions tires, maintaining them in a vertical orientation during the X-ray process. This method as supplier present reduces the risk of structural deformation that can occur with manual or less sophisticated handling methods, ensuring the tire retains its integrity for accurate imaging. [16]

Vertical X-ray Positioning

The vertical setup for X-ray imaging is critical for preventing the tire from deforming under its weight, a challenge commonly encountered in horizontal X-ray arrangements. This orientation aids in achieving clearer, more accurate X-ray images, which are essential for detailed inspections. [16]

Coll-Tech Automatic Defect Recognition Software:

The CTXS Plus is equipped with sophisticated software that automates the detection of abnormalities across all tire areas. The integration of artificial intelligence and classical algorithms enhances the system's capability to identify a wide range of defect types efficiently and accurately. This will be described more in the chapter below. [16]

Operational Advantages

- The system's compact design minimizes space requirements, an essential feature for facilities with limited operational areas. Its ability to fit within standard shipping containers also simplifies logistics, reducing costs and complexities associated with transportation and installation.
- Designed for low maintenance and ease of use, the *CTXS Plus* offers a lower total life cycle cost. Quick start-up capabilities and reduced maintenance requirements contribute significantly to operational efficiency, making it an economically viable option for high-throughput manufacturing settings.
- The *CTXS Plus's* ADR software is adept at detecting both generic and high-risk defects. The precise rotation and stable vertical positioning of the tire during the X-ray process ensure high-quality imaging, which is crucial for detecting minute anomalies.
- The X-ray tube of the *CTXS Plus* operates at up to 100 kV and 6 mA, with an emission angle optimized for comprehensive tire coverage. The high-resolution C-shape detector enhances image quality, providing detailed insights into the tire's internal structure. [16]



Figure 13 Micropoise X-ray machine solution [16]

2.4.1.2 ADR software

The Coll-Tech X-Ray ADR software is a component of the Micro-Poise suite of tools for X-ray inspection and Automatic Defect Recognition (ADR) designed for tire manufacturing. It plays a crucial role in ensuring the quality and reliability of tires through sophisticated X-ray imaging analysis. [17]

ADR software system can recognize multiple layers within a tire, handling up to three breaker layers in addition to the ply. It is designed to detect, track, and differentiate each wire in any tire layer and provides three-dimensional metric calculations. Recognized for its rapid processing capabilities, the system automatically identifies anomalies from X-ray images across all tire areas without dependence on the tire type. [17]

Key Features:

- **Tire Viewer Module:** Enables operators to quickly locate specific anomalies identified by the software.
- **Communication Capabilities:** Interfaces with all Micro-Poise X-ray machines and can be adapted to work with third-party X-ray systems through its communication module.
- **User Configuration Options:** Allows operators to adjust tolerances and appearances to suit specific operational requirements.
- **Database and Recipe Management:** Supports the management and storage of tire specifications and manufacturing data.
- **Data Analysis:** Incorporates tools for historical data collection and statistical analysis, aiding in informed decision-making. [17]

Detection Features

The software is engineered to detect a variety of defects and anomalies:

- **Bead Disorders:** Identifies issues related to bead structure and alignment [17]

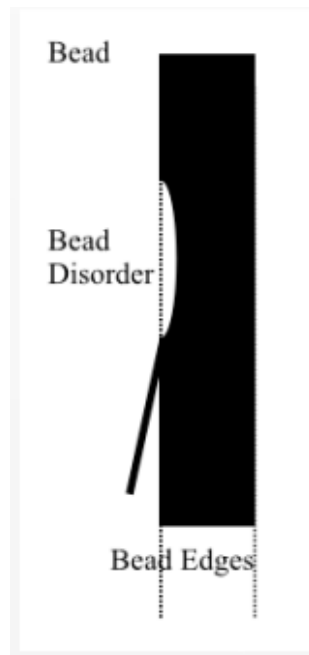

Figure 14 Bead disorder detected by ADR from Micropoise [17]

- Off-center Breakers: Detects misalignments within the breaker layers

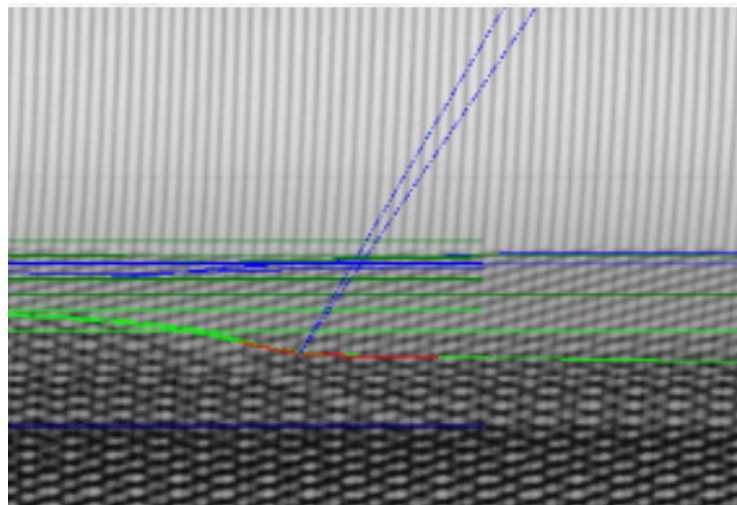

Figure 15 Findings in breaker by ADR from Micropoise [17]

- Body Ply Arrangements: Identifies issues such as opening or touching wires

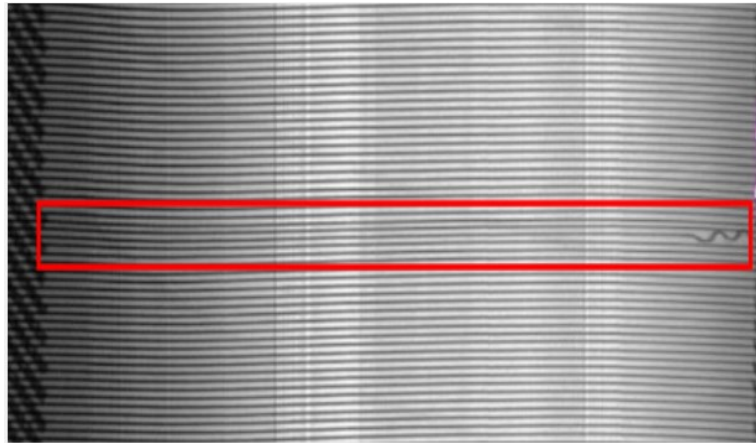

Figure 16 Body Ply findings with ADR from Micropoise [17]

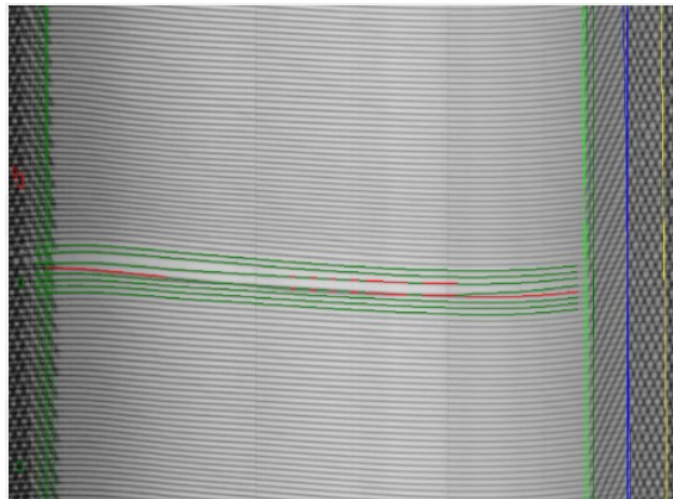

Figure 17 Ply automatically detected with ADR from Micropoise [17]

- Foreign Objects: Locates unwanted materials embedded within the tire
- Air Bubbles: Detects blisters both in the sidewall and underneath the chafer

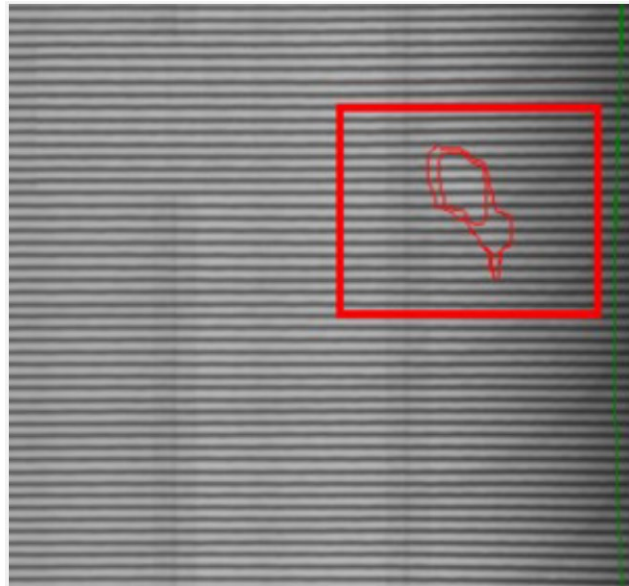

Figure 18: Air bubble detected by ADR from Micropoise [17]

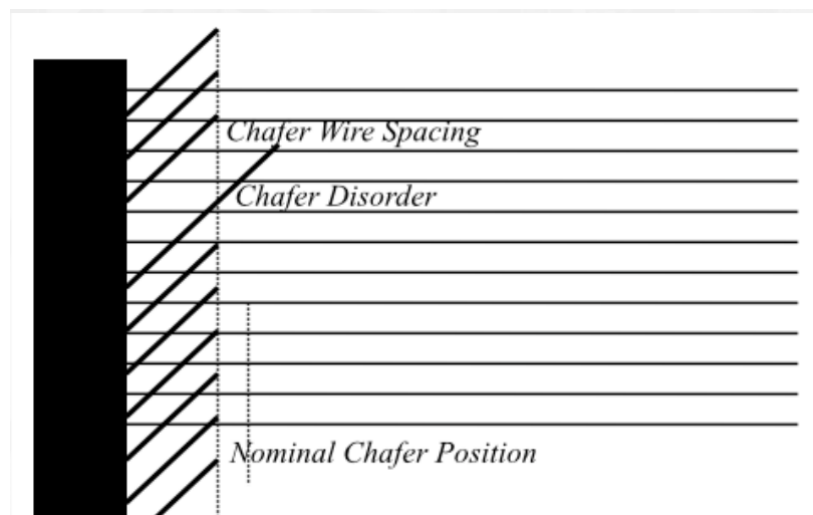

Figure 19 Chafer automatic detection with ADR from Micropoise [17]

- RFID Detection Under Chafer: Checks for the correct placement and characteristics of RFID tags

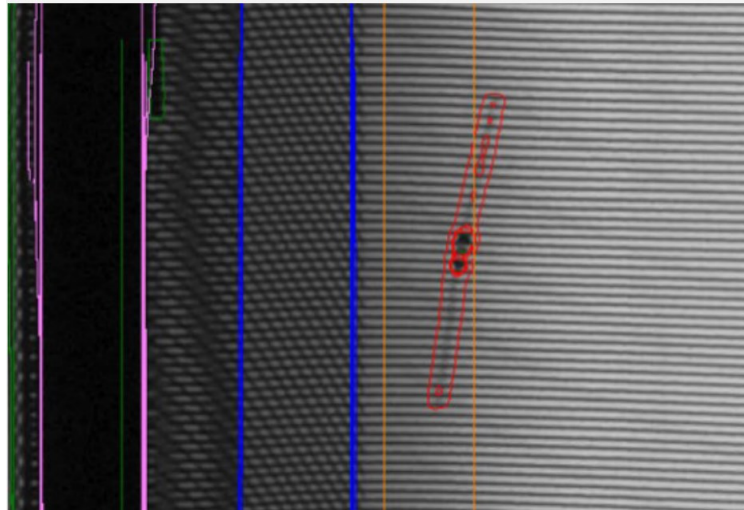

Figure 20: RFID detected by ADR from Micropoise [17]

- Comprehensive Ply and Bead Analysis: Evaluates ply-turn-up distances, bead width disorders, and other related metrics

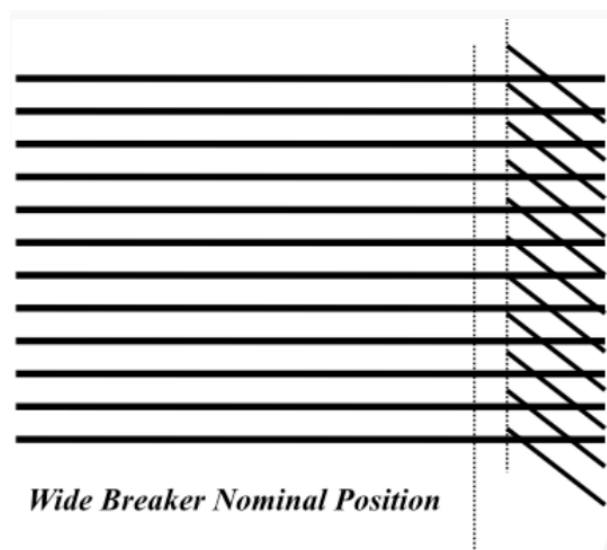

Figure 21 Ply-Turn-Up detected by ADR from Micropoise [17]

Micro-Poise's software capabilities mark a significant advancement in the field of tire inspection, offering a highly automated solution that minimizes the need for human intervention. The software is capable of running entirely autonomously, governed by sophisticated algorithms that control the inspection process. The advanced automation enabled by Micro-Poise's software significantly reduces the human resources required for tire inspection. On average, the necessity for a human grader is reduced to half a grader per shift for up to three X-ray devices. Facilities operating more than three X-ray devices require a full-time grader

present throughout the shift to oversee the operations and ensure the optimal functioning of the inspection systems. Micro-Poise employs a four-layer AI system within its inspection software, enhancing the precision and scope of tire anomaly detection and classification:

E.g. one layer is responsible for identifying imperfections in the tire, utilizing advanced imaging and pattern recognition technologies. The next layer, used after the detection of anomalies is for classifying according to their types and characteristics, aiding in determining the appropriate response or correction required. Utilizing pixel-to-millimeter (px-mm) technology, the software can also calculate the actual size of detected features in millimeters. This capability is crucial for assessing whether an anomaly falls within acceptable manufacturing tolerances or constitutes a genuine defect. By analyzing data collected over periods, such as three weeks, the system can automatically generate production recipes. This feature is particularly useful for rapid deployment and operational scaling in new manufacturing facilities, enabling swift roll-outs and adjustments based on real-time data insights. [16] [17]

By reducing the dependency on manual grading and enhancing the precision of defect detection and classification, Micro-Poise systems not only streamline the production process but also ensure higher quality standards. These innovations contribute significantly to operational efficiency, cost reduction, and product reliability in tire manufacturing industries, supporting the ongoing evolution toward fully automated manufacturing solutions. By automating tire inspections, the Coll-Tech X-Ray ADR software reduces the reliance on manual checks, thus decreasing operational costs and enhancing the efficiency of the production cycle. This system ensures a consistent and thorough inspection process, reducing the likelihood of human error and enhancing product reliability. The system's adaptability allows it to be integrated with a variety of X-ray machines, making it a flexible option for different manufacturing environments. It is suitable for inspecting radial tires across passenger vehicles, trucks, and buses, offering broad usability. [16] [17]

Micro-Poise also offers support for its products, including technical services, spare parts, machine upgrades, and preventative maintenance. This ensures that the systems continue to operate efficiently and remain up to date with technological advancements. [16]

2.4.2 Yxlon

2.4.2.1 *Yxlon machine*

The YXLON MTIS X-ray inspection system is engineered to fulfill the demands of quality assurance in radial tire manufacturing for both passenger cars and trucks. This system offers seamless integration into production lines, supporting continuous operational demands with an uptime exceeding 95% (supplier number), which ensures reliability in high-volume manufacturing environments. [1]

The MTIS system features a mechanical setup with four synchronously driven spindles and a precise linear axis system powered by servo motors. This configuration allows for the gentle and accurate handling of tires, ensuring that they are rotated without slipping or deformation, which is critical for consistent inspection results. The integration of a shielded X-ray source, optimized for stability, and the UScan3 line detector ensures superior image quality. The UScan3 detector, specifically designed for tire inspection, delivers images with high contrast and clarity at a 16-bit dynamic resolution, facilitating the detection of minute anomalies within the tire structure. The system adheres to the stringent safety standards set by radiation laws and is fully compliant with the European machinery directive. Optional adaptations to meet local standards, such as OSHA/UL, are also available, ensuring the system's versatility and safety across different operational jurisdictions. [1]

Technical Specifications

- The system can work with tires with widths ranging from 100 to 508 mm and inner diameters from 13 to 26 inches, supporting a maximum tire weight of 160 kg. This allows the MTIS system to handle a broad spectrum of tire sizes used in both passenger and commercial vehicles.
- Occupying a physical space of approximately 5,400 mm x 5,100 mm x 2,700 mm, the system incorporates a 100 kV / 300 W X-ray tube, ensuring deep penetration and clear imaging across dense tire components. [1]

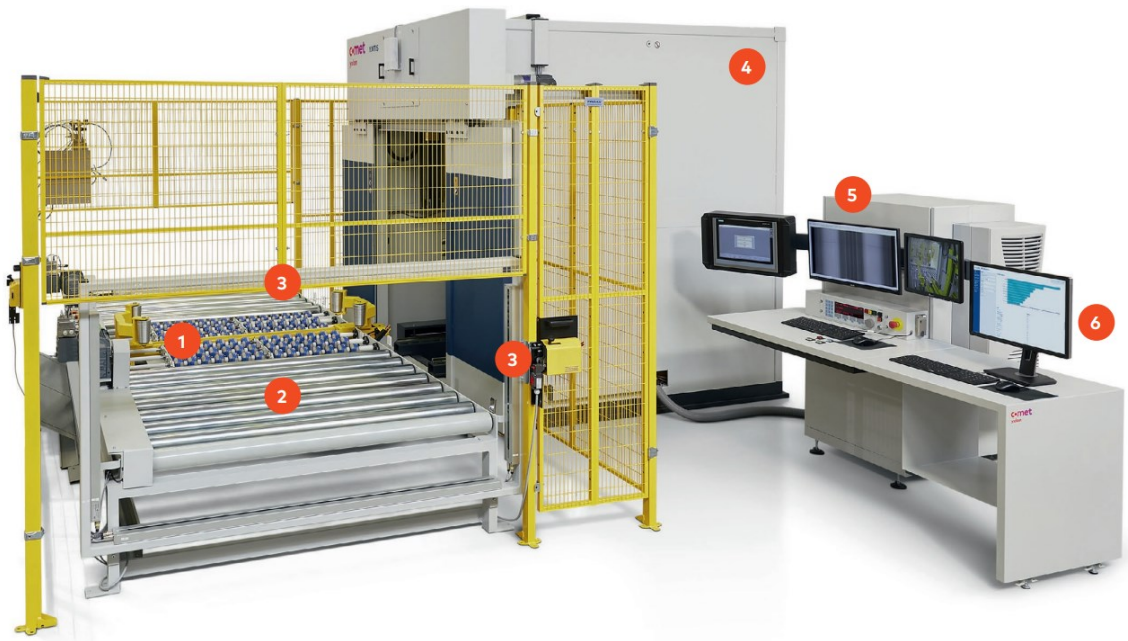

Figure 22 X-ray inspection system MTIS [1]

Description:

1. Loading arm
2. Conveyor
3. Tire ID station
4. X-ray cabinet
5. Operator console
6. Result Statistics Station



Figure 23 Tire manipulator for loading tires into MTIS system from conveying system [1]



Figure 24 UScan3 line detector and 4-spindle tire manipulator [1]

2.4.2.2 Inspection Software - Y.TireAXIS

This software forms the core of the MTIS system's operational intelligence, offering tools for both fully automated and supervised inspection processes. It analyzes the entire tire in one scan, assessing the alignment, and consistency of components, and identifying any anomalies. [1]

Defect Detection and Analysis: Y.TireAXIS excels in examinations such as:

- **Belt alignment and positioning:** Ensuring the belts are centered and correctly angled.
- **Turnup and chafer inspection:** Verifying the correct position and height.
- **Steel cord analysis:** Checking for spacing issues, including crossed or touching cords, and identifying wavy cords.
- **Foreign material detection:** Locating any unwanted materials or air voids within the tire structure. [1]

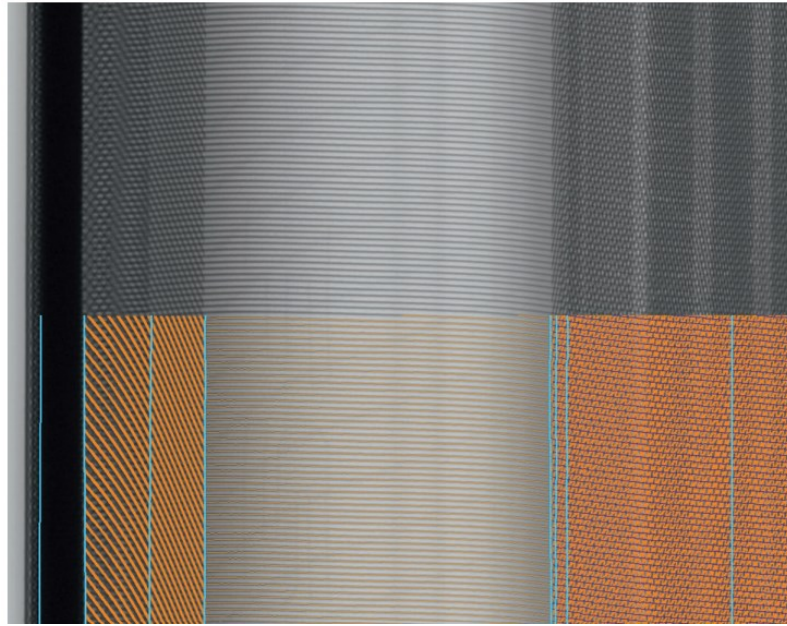

Figure 25 Y.TireAXIS recognizes of the individual components of the tire and analyzes the structure, position, and dimensions. [1]

The software not only supports the detection of anomalies but also collects data sets for each tire inspected. This data is crucial for statistical process control, helping manufacturers to monitor, adjust, and enhance their production processes.

Y.TireAXIS is designed to integrate smoothly into existing production lines with features that support easy setup and operation. The interface provides a live view mode, reducing strain on operators and enhancing the ability to spot defects in real time. Service Engine 4.0: YXLON's commitment to service includes Service Engine 4.0, offering a modular approach to system maintenance and upgrades. This service framework ensures operational safety, maximizes system availability, and extends the product lifetime while providing fast and reliable support through remote access and on-site service. With a worldwide network of service centers, YXLON ensures that support and expertise are readily available, helping to maintain the system's performance and adapt to evolving industry requirements. [1]

2.4.3 CyXplus

2.4.3.1 *CyXplus machine*

CyXplus offers a range of X-ray inspection systems designed for radial tires, including models such as PCR12-25 for passenger car radial (PCR) tires and TBR15-27 for truck and bus radial (TBR) tires. These systems are engineered to handle tires within specific inner diameter ranges, enhancing the precision and effectiveness of internal structure inspections. [18]

System Design and Functionality

- **Horizontal Handling:** Both PCR and TBR machines utilize a horizontal tire handling approach throughout the inspection process. This orientation is critical for several reasons:
 - **Optimized Cycle Time:** Horizontal handling streamlines the inspection process, allowing for quicker transitions and reducing overall cycle times.
 - **Reduced Shape Distortion:** Maintaining the tire in a horizontal position minimizes distortions during the X-ray scanning, ensuring the accuracy and reliability of the captured images.
 - **Lower Maintenance Costs:** The horizontal system requires fewer mechanical adjustments and manipulations, decreasing the frequency and cost of maintenance.
 - **Space Efficiency:** The design of the lead cabin is compact, making it suitable for environments where space conservation is crucial.
- **OTRX Range for Larger Tires:** The OTRX series is specifically developed for Off-The-Road (OTR) tire inspection, catering to a wide range of tire sizes from 20" ID to 63" ID. This series stands out by offering high image quality, automated cycles, and optimized processing times, making it a unique solution in the market. [18]



Figure 26 CyXplus machine solution

2.4.3.2 *CyXplus Software Solutions*

CyXmark Software:

This component focuses on the inspection of tire markings, including regulatory, commercial, and production marks. It utilizes optical character recognition (OCR), pattern matching, and logo identification techniques to ensure that all markings meet quality standards. [18]

CyXpert Software:

Known as the Automatic Defect Recognition (ADR) software in the tire industry, CyXpert enhances the functionality of CyXplus inspection systems. It analyzes tire X-ray images to detect a variety of defects with high accuracy, significantly optimizing the X-ray inspection process. The software operates efficiently in both automatic and semi-automatic modes, maintaining the inspection cycle time under 22 seconds in automatic settings. [18]

CyXscan Cross Section Scanning System:

The CyXscan system consists of a scanning system, a dedicated workstation, and CyXscan software with an embedded license. This setup is primarily used by Engineering or Quality Assurance departments for detailed examination of tire cross-sections sampled from production. The system facilitates millimetric measurements of tire cross-sections without physical contact, preserving the integrity of the samples. It is particularly valuable for tire manufacturers for its precision and the ability to quickly analyze cut cross-sections. [18]

Building on its expertise in X-ray inspection, CyXplus has also developed a 2D computed tomography solution that can generate cross-sectional images of tires in seconds without destroying them. This innovation significantly reduces the time required for cross-sectional analysis from hours to under three minutes, enabling its integration directly on production lines. [18]

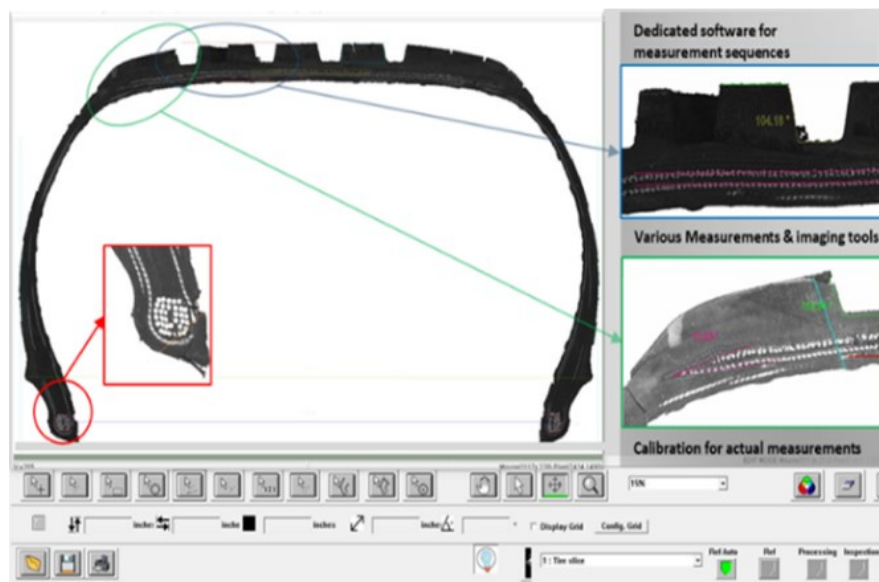

Figure 27 Example from CyXscan software environment [18]

Benefits and Application of CyXplus Systems:

- **Enhanced Inspection Accuracy:** With a resolution accuracy of 0.4 mm, CyXpert software can identify defects in critical tire areas such as the tread, sidewall, and bead. The system's capability to detect intricate details like cord integrity, belt extraction, and air traps makes it invaluable for maintaining high-quality standards.
- **Data-Driven Quality Control:** CyXplus systems not only perform inspections but also collect comprehensive data that can be used for statistical analysis and quality control. This data helps tire manufacturers monitor and refine their production processes, ensuring consistent product quality.
- **Adaptability and Customization:** The modular design of CyXplus systems allows for easy adaptation to specific production requirements. The availability of both automatic and manual operation modes provides flexibility in how inspections are conducted, accommodating varying operational needs. [18]

2.4.4 Other companies on the market

Other companies in the X-ray equipment market do not have accessible documents or presentations and generally do not provide detailed information about their systems. Therefore, only their names and the machine look are mentioned.

5. Alfamation



Figure 28 Solution from company Alfamation [19]

6. Mayer



Figure 29 Solution from company Mayer [20]

II. ANALYSIS

3 AIM OF THESIS AND METHODOLOGY

In the subsequent chapters of this thesis, specifically Chapters 4 through 6, the focus will be on a comprehensive exploration and enhancement of in-house artificial intelligence models for tire inspection, juxtaposed with the integration and evaluation of external solutions. This examination will include a detailed analysis of operational costs, the benefits of various technologies, and the strategic implementation of selected solutions within Continental's manufacturing processes.

Chapter 4 delves into the development of an in-house AI model initially proposed by author Dominik Arend. The chapter begins with a detailed assessment of the raw data available from Continental's X-ray devices, including image resolution specifics and the categorization of tire quality based on operator input. It will elaborate on the methodologies used to preprocess this data, ensuring that it aligns with the operational needs of AI algorithms, which involves the standardization of image dimensions and the innovative use of overlapping image segments for enhanced defect detection. Further, this chapter will explore the implementation strategies of the AI model within the production environment, detailing the segmentation techniques and the training of the model using defect-free images to optimize its anomaly detection capabilities.

In Chapter 5, the narrative shifts to a comparative analysis between the in-house AI solution and external technologies, notably the Micropoise ADR system. This chapter will outline the criteria for evaluating both systems, including their ability to integrate within existing infrastructure, cost implications, operational efficiencies, and the quality of inspection. The analysis will draw on data-driven metrics to establish the strengths and limitations of each solution.

Chapter 6 details the strategic rollout of the Micropoise ADR solution, selected based on the comprehensive evaluations discussed in Chapter 5. This chapter will provide a roadmap for the deployment of the automated X-ray inspection system, addressing the logistical, technical, and operational aspects necessary for successful implementation across Continental's designated facilities.

4 IN-HOUSE AI MODEL

One solution with the potential to advance tire inspection automation is the internally developed AI model initially created by Dominik Arend [21]. In his thesis, he explored the intricacies and possibilities of deploying such a model in a production environment. He developed a foundational model, defined its capabilities, outlined the necessary steps for its implementation and conducted initial tests. Further testing and development of this model are now part of my work at Continental, specifically within the scope of a project designed for this purpose. The following description will frequently reference his work. [21]

4.1 Description

4.1.1 Working with raw data

To implement different types of algorithms, test various architectures, and train and process data for our internal AI model we had to identify the available data and understand the communication between the complex X-ray device and the communication infrastructure at Continental's manufacturing plants.

The X-ray device provides several types of data. Firstly, it outputs images in JPG format with specific resolutions based on the article and the calibration of the X-ray machine. The height (more precisely the length of the image) varies from 7,600 pixels to 18,000 pixels, while the width is constant at 2,469 px due to the machine's design. Another set of data available for our algorithm consists of operator decisions. Operators (sometimes with the assistance of software running on certain X-ray machines) examine the machine's results to determine whether a product can be labeled as *O* (Original Equipment Manufacturer Quality), indicating that the item can proceed to the final processing department and then be released to the market. If not, the operator enters an *S* (Suspicious) tag into the system. Such tires are then forwarded to a higher-level grader for further inspection, who decides whether the tire can be reworked (marked as *R* – Replacement or Rework) or must be scrapped. The grader can assign final labels: *O* for good tires, *R* for reworkable tires, or *X* for tires to be scrapped. Additional data includes the description and location of any detected defects and measured tolerances (or more precisely intolerances). [21]

All this information is processed by the *MCAT* (Material Flow Control and Tracking System) - a specific Continental decision system containing data such as barcodes, operator/grader decisions, detected intolerances, dates, and times.

For context, nearly 92% of the images examined were marked with the *O* label, 3% with the *X* (Scrap), 1% with the *S* (Suspicious), and the remaining 7% with the *R* (Rework). For some X-ray images, no labels were available when querying data from the *MCAT* system, so they were excluded from further analysis. Also, 1% of tires marked with the *S* label were categorized by the operator but not yet reviewed by a grader, leading to their exclusion from further analysis. The *X* label was assigned to some tires during various inspection phases, like uniformity measurement. Out of the 3% of tires labeled *X*, only some exhibited visible defects during X-ray inspection. [21]

Additionally, 7% of the tires were marked with the *R* label. However, only a small fraction had defect codes based on X-ray analysis, while others were assessed by different methods. For 7% of tires marked *R*, the assessment method is unclear, as some may share defect codes with faulty tires, potentially due to rework. When a tire is marked for rework, it falls into the faulty category even if it is defect-free after rework. Other tires in the *R* category might have undergone significant rework and are defect-free but cannot be classified as *O* due to their previous rework status. These tires are sold as replacement tires with the *R* label.

Also, some tires received the *R* label for further X-ray screening, regardless of whether they exhibited defects. Due to these ambiguities, only tires labeled *O* and *X* were used to develop the algorithm to avoid unclear data. As a result, the data set includes over 250,000 defect-free X-ray images and nearly 500 images with identifiable defects. [21]

4.1.2 Preparation of data

To link the X-ray images with the corresponding labels from the *MCAT* data, it's essential to use a consistent naming convention that incorporates key identifiers. This method enhances data organization and retrieval.

As already described the naming format for each JPG. JPG image includes the label, the article number, and the barcode derived from the *MCAT* system. The structure follows the

pattern `l_Label_a_ArticleNumber_b_Barcode.jpg`. An example of this would be `l_O_a_0514090000_b_6146131587.jpg`. Using lowercase letters to represent "label," "article number," and "barcode" creates a straightforward way to categorize and sort files based on one or more of these criteria. [21]

To ensure consistency among the X-ray images, it is necessary to standardize the image sizes, particularly since the image width remains constant, while the height can vary. Having uniform image dimensions simplifies the process of training an autoencoder, which typically requires consistent input sizes. One effective approach is to divide the images into overlapping segments, which helps avoid information loss that might occur with compression or when splitting the images into directly adjacent sections.

An expert in Continental's tire X-ray defect detection was consulted to determine the optimal way to subdivide the images. The expert suggested a horizontal subdivision of each image into sections approximately 128 pixels in height. This approach was chosen because it offers a practical way to detect potential defects without compromising the accuracy of the analysis. The expert determined that this size was sufficient to capture critical details and that any defect running along the width of the tire could be identified through this subdivision strategy. Given the round shape of tires and the varying distance between the X-ray source and the detector, the size of objects in the X-ray images might differ based on their location. To estimate the pixel-to-real-size conversion, a tire with a known circumference of 3 meters and an X-ray image length of 18,000 pixels was used to calculate a conversion ratio. This ratio indicated approximately 6 pixels per millimeter, but it's important to note that this is a general estimate and may not be consistently applicable across all scenarios. The consultation with the expert also addressed the possibility of vertical subdivision, along the running direction of the tire, to capture different regions like the tread or bead. However, it was concluded that horizontal segmentation provided a reliable means of identifying defects, given that many anomalies would be evident within a 128-pixel-high section. While vertical segmentation could offer additional insights, horizontal subdivision was deemed sufficient for the scope of this analysis. This method allows for capturing the necessary details and addressing any positional variations across the tire's length. [21]

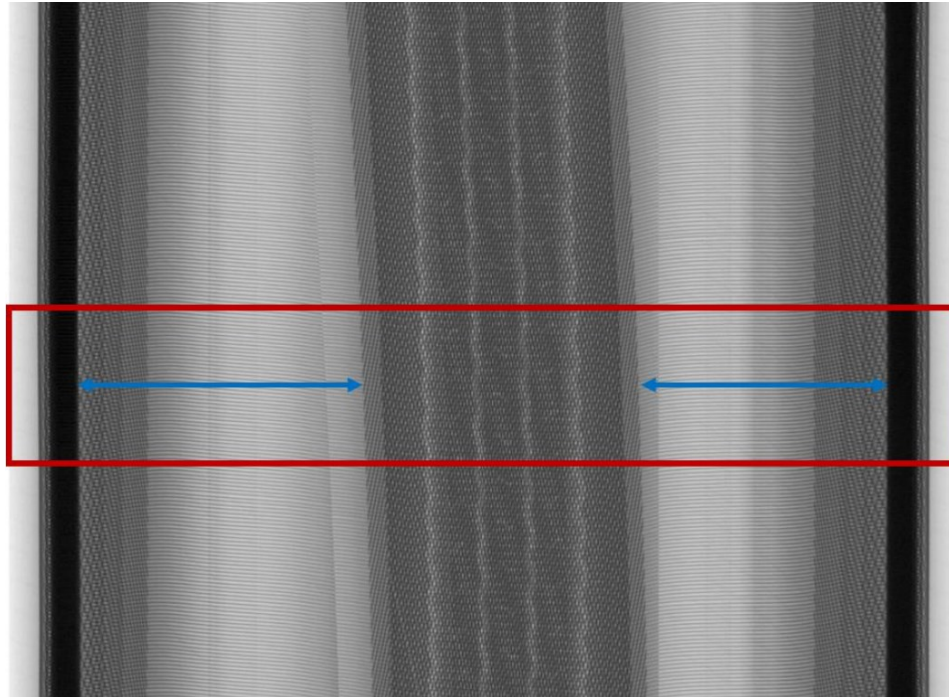

Figure 30 Tire with asymmetric belt [21]

In **Figure 30**, the defect is apparent throughout the entire circumference of the tire. This visibility extends to individual sections of the X-ray image, marked in red, where the belt appears misaligned or shifted away from the tire's center relative to the beads.

To accurately detect certain defects, both edge areas of the belt layers must be visible within a single image, as these defects might not be as noticeable in all images of the same type. Similar issues can also occur near the tire beads, reinforcing the need for a comprehensive view within a single image. This is why horizontal subdivisions are effective, while vertical subdivisions may not be suitable for reliable defect detection. [21]

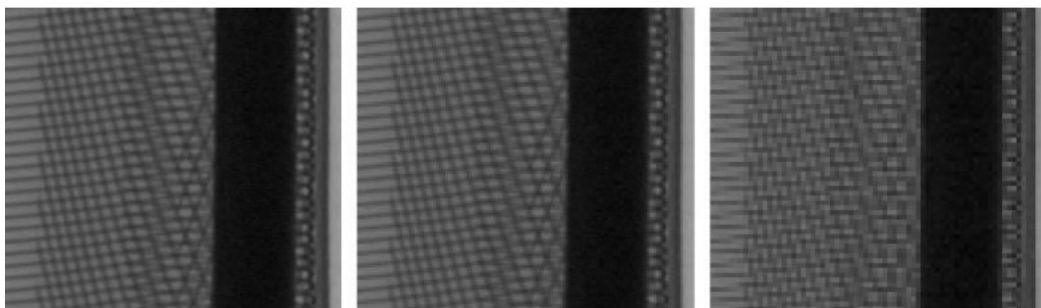

Figure 31 Image section with scaling factors of 1, $\frac{1}{2}$, and $\frac{1}{4}$ [21]

To examine whether image compression is feasible, tests were conducted using different compression factors. **Figure 31** compares three identical image sections with compression factors of 1, $\frac{1}{2}$, and $\frac{1}{4}$. The results indicate that at a compression factor of $\frac{1}{2}$, the defect remains clearly visible. However, at $\frac{1}{4}$, the defect becomes obscured, suggesting that the compression factor shouldn't be less than $\frac{1}{2}$ to maintain clarity. [21]

Manual compression might not be necessary, as the autoencoder's convolutional layer can offer better compression while preserving more relevant image information. The convolutional layer uses multiple filters per reduction step, providing a more controlled compression process than manual image compression. To reliably detect all potential defects, images are subdivided into sections of 256 pixels in height, with an overlap of 128 pixels between each segment. This method avoids loss of information while ensuring that different image heights don't pose a problem. Larger images simply generate more sections. To keep track of the subdivided images, the naming convention includes the original pixel position in the height of the image and the indication of the width. For example, the file name `l_O_a_0514090000_b_6146131587_s_fullwidth_512.jpg` provides information about the label, article number, barcode, and section position. This naming strategy helps in aligning the subdivided sections with the original X-ray images. [21]

Overall, the subdivision and compression strategies are designed to maintain the integrity of the data, allowing for consistent analysis and reducing the impact of variable image heights or sizes on the detection of critical defects. [21]

4.1.3 Training on anomaly dataset

For the autoencoder training, only X-ray images without defects should be used to ensure optimal results. However, even tires labeled *O* often contain an anomaly known as a *Splice marker*, which indicates where the tire's ply ends overlap. This marker can be identified in the X-ray image and thus must be avoided during training because it represents an anomaly.



Figure 32 X-ray image with Splice marker

To maintain a balanced training set, the number of X-ray images for each tire article should be as evenly distributed as possible, providing the autoencoder with a consistent learning environment. It is assumed that different X-ray images of tires with the same label from the same article exhibit minimal variations, given that they are captured on the same X-ray machine. Therefore, training with one X-ray image per article should be sufficient to avoid redundancy and keep the training set manageable in size. After manually removing segments containing splice markers, the training set comprises 28 918 image segments derived from one X-ray image per article from 304 different articles. The number of segments per article varies based on tire size; larger tires yield more segments due to their greater circumference. Even with some variance in the exact number of segments per article, the training set is consistent enough to allow for direct comparison between autoencoder architectures. [21]

Once an autoencoder architecture has been trained, it must be evaluated to determine its effectiveness in distinguishing between normal and abnormal image data. This is accomplished by comparing the reconstruction error of abnormal image segments with that of defect-free segments from the same article. A greater difference between these errors indicates a better-performing architecture. To conduct this evaluation, an anomaly set containing only image segments with defects is created. This set should have a balanced distribution of various defects to allow for a fair assessment of the architectures. For this purpose, one image segment is selected for each of the 39 X-ray defect codes. These segments are taken from a random selection of articles and tires based solely on their defect codes, without regard to the visibility or ease of detecting the defect. This approach ensures a comprehensive evaluation of the architecture's ability to detect a wide range of anomalies, from those readily apparent to the human eye to those that are more challenging to identify. [21]

4.1.4 “Postprocessing”

Once the optimal autoencoder architecture for detecting anomalies is identified, the next step is to enhance it for classifying the detected anomalies. This requires defining the error classes to categorize the different types of defects. To classify defects, the existing X-ray defect codes are used, as each tire labeled with an "X" has corresponding defect codes. With splice markers removed from the training set, they are expected to be identified as anomalies during classification. To differentiate between splice markers and defects, a separate class for splice markers is created, resulting in a total of 40 classes for classification. Adjusting the

autoencoder architecture to accommodate new classes involves retraining, but only the modified layers need to be retrained, leaving the previously learned layers intact. [21]

The X-ray images used in the training and evaluation process need to be standardized to ensure uniformity. Variability in X-ray machine settings across different plants can lead to differences in brightness and contrast. To address this, each image is processed to have a mean of 0 and a standard deviation of 1, allowing consistent gray value ranges. This standardization is crucial for machine learning algorithms like autoencoders, which require uniform input data. Standardization is achieved by subtracting the mean gray value from each pixel and then dividing by the standard deviation. This transformation, detailed in the equations below, ensures that all images have a consistent gray value distribution. [21]

$$x_{stand} = \frac{x - \bar{X}}{\sqrt{\frac{1}{n-1} \sum_{i=1}^n (x_i - \bar{X})^2}} \quad (2)$$

In quotation (2) The variable x_{stand} denotes the standardized gray value of a pixel, while x represents the original gray value of that pixel. The term n refers to the total number of pixels in an X-ray image, and \bar{X} is the mean of all pixel gray values in the image, as given in equation (3) below. [21]

$$\bar{X} = \frac{1}{n} \sum_{i=1}^n x_i \quad (3)$$

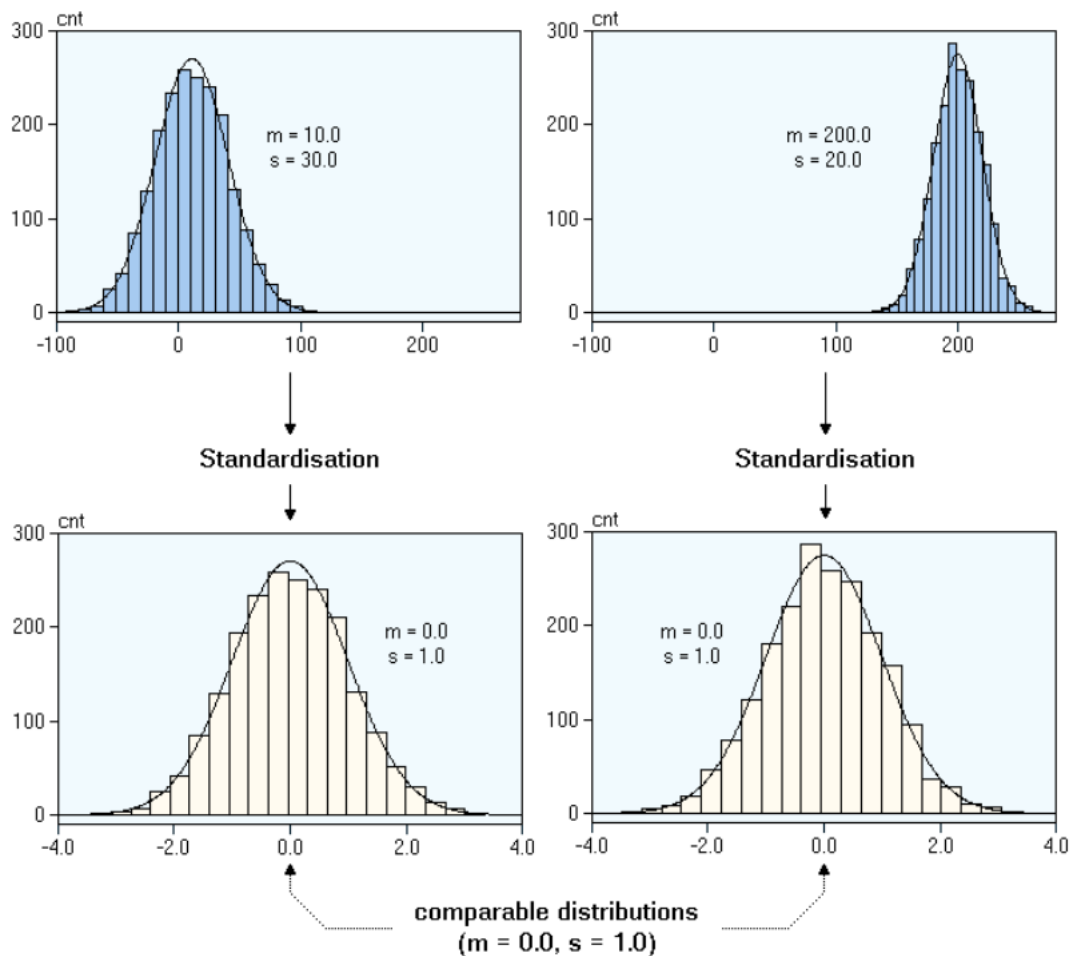

Figure 33: Normalization with the distribution of fitting the gray value [21]

Figure 33 illustrates how this standardization aligns different distributions into alignment, enabling direct comparisons despite initial differences in brightness and contrast.

However, standardized images cannot be displayed in their original form. To convert them back to a displayable format, the standardized values must be multiplied by the original image's standard deviation and then added to the mean value. This process is known as reverse standardization, allowing the converted images to be viewed again. Overall, this approach standardizes X-ray images for consistent processing and provides a reliable method for training and evaluating autoencoders in the context of anomaly detection and classification. [21]

4.1.5 Training and Evaluation of Autoencoders Architectures

To compare different autoencoder architectures, several key parameters are defined, including the number of layers, the number of filters per layer, and the step size in the convolutional layers. The training process for these architectures requires significant computing power, which is efficiently managed using graphical processors due to their parallel processing capabilities.

The training of these autoencoder architectures takes place in *Continental Datalake*, an infrastructure that uses *Amazon Web Services (AWS)* for data storage, processing, and visualization. *AWS* provides preconfigured instances, such as *p2.xlarge*, with high-performance GPUs like NVIDIA K80, allowing scalable training with TensorFlow and other machine learning frameworks. This setup enables simultaneous training of multiple architectures, enhancing the efficiency of the process. Symmetry in autoencoder design allows for shared weights between encoder and decoder layers, reducing the number of parameters and minimizing overfitting risks. To achieve this, custom layers are created in TensorFlow to facilitate weight sharing, considering factors like padding and varying step sizes. This approach leverages TensorFlow's efficient C++ backend, ensuring optimized performance. [21]

Regarding convolutional layers, pooling operations are replaced with 2-stride convolution, simplifying the architecture. This method is used consistently across all trained networks, with configurations that alternate step sizes of 1 and 2, or exclusively use a twofold step size. The training metrics focus on evaluating the similarity between the input and output images, crucial for autoencoder performance. Metrics like Mean Absolute Error (*MAE*) and Mean Squared Error (*MSE*) assess the discrepancy between these images, with *MSE* emphasizing larger deviations. The chosen metric reflects the importance of maintaining accuracy while allowing for some image compression during the autoencoder process. [21]

4.1.6 Performance Evaluation of Autoencoder Architectures

Each autoencoder architecture has a training error that reflects its ability to reconstruct the input image. While the training error does not directly indicate the architecture's

effectiveness in identifying defects, a significant difference between the reconstruction error of defect-free images and that of defective ones suggests an ability to detect anomalies.

To compare autoencoder architectures, X-ray images are categorized into two groups based on their labels: class "O" for defect-free images and class "X" for those with defects. Since defects typically occupy only a small portion of an X-ray image, an anomaly set is created to focus on segments with actual defects. The expected reconstruction error (E) is derived from the mean and standard deviation of the reconstruction error for 10 defect-free image segments. The expected error is calculated in equation (4) as follows: [21]

$$E = \frac{1}{10} \sum_{i=1}^{10} MSE_{normal,i} \quad (4)$$

where $MSE_{normal,i}$ represents the Mean Squared Error for the i -th segment. The standard deviation (σ) is calculated from the expected error in equation (5):

$$\sigma = \sqrt{\frac{1}{9} \sum_{i=1}^{10} (MSE_{normal,i} - E)^2} \quad (5)$$

The threshold for distinguishing between normal and abnormal segments is given by equation (6):

$$T = E + \sigma \quad (6)$$

To assess each autoencoder architecture, the difference between the reconstruction error for defective segments and the threshold value is calculated. This difference MSE_{diff} is in equation (7) determined as:

$$MSE_{diff} = MSE_{abnormal} - T \quad (7)$$

where $MSE_{abnormal}$ is the Mean Squared Error for the defective segment, and T is the threshold value. A larger difference indicates better differentiation between defective and defect-free images. [21]

To compare different architectures, the median of the difference values across all 39 segments in the anomaly set is used. The median is less sensitive to extreme values or outliers, providing a more robust measure for comparison. A positive median indicates that at least half of the difference values are also positive, suggesting that the architecture can effectively distinguish between normal and defective segments.

The architecture with the highest median across the difference values can be considered the best-performing. However, further analysis may be needed to address cases where the difference values are small or even negative. This requires examining individual segments to identify scenarios where the architecture might struggle to detect defects. [21]

4.1.7 Comparison of Autoencoder Architectures

This section presents a comparison of different autoencoder architectures, focusing on their ability to distinguish between defective and defect-free image segments. It provides a summary of the various architectures and their performance in terms of the median difference value, which indicates how well an architecture can differentiate between normal and abnormal segments. [21]

Chyba! Chybný odkaz na záložku. shows a list of autoencoder architectures along with their configurations and the corresponding difference values. The architectures vary in terms of the number of encoder layers, filter sizes, step sizes, and difference values (median). The best architecture has the highest difference value, indicating its ability to effectively differentiate between defective and defect-free image segments. [21]

Based on the table, architecture 14 with 11 encoder layers (22 layers in total) and a twofold step size has the highest median difference value, indicating that it is the best architecture for distinguishing between defective and defect-free image segments. Architectures with a median difference value greater than 1 are highlighted in green, showing that they can successfully differentiate between normal and defective segments. [21]

Table 1 Comparison of Trained Autoencoder Architectures [21]

Index	Num. Encoder layers	Filter sizes	Step size	Difference value (median)
1	3	16-32-64	2-Stride	0,04
2	4	16-32-64-128	2-Stride	-0,07
3	5	16-32-64-128-256	2-Stride	-0,04
4	6	16-16-32-32-64-64	Alternating	0,16
5	6	16-32-64-128-128-256	2-Stride	0,79
6	7	32-32-64-64-128-128-256	2-Stride	4,35
7	8	16-16-32-32-64-64-128-128	Alternating	-0,27
8	8	32-32-64-64-128-128-256-256	2-Stride	7,56
9	8	32-32-64-128-128-256-256-512	2-Stride	4,72
10	9	32-32-64-64-128-128-256-256-512	2-Stride	8,23
11	10	16-16-32-32-64-64-128-128-256-256	Alternating	0,17
12	10	16-16-32-32-64-64-128-128-256-256	2-Stride	11,20
13	10	32-32-64-64-128-128-256-256-512-512	2-Stride	9,71
14	11	32-32-64-64-128-128-256-256-256-512-512	2-Stride	13,09
15	12	16-16-32-32-64-64-128-128-128-128-256-256	Alternating	1,01
16	14	32-32-32-32-64-64-64-64-128-128-128-128-256-256	Alternating	4,33

However, some architectures exhibit negative difference values, suggesting that they have difficulty distinguishing between defective and defect-free segments. This can occur due to variations in the training data or the method used to calculate the threshold value. It's important to note that the threshold value can be adjusted for better differentiation, and the number of image segments used for training can be increased to ensure reliable differentiation. [21]

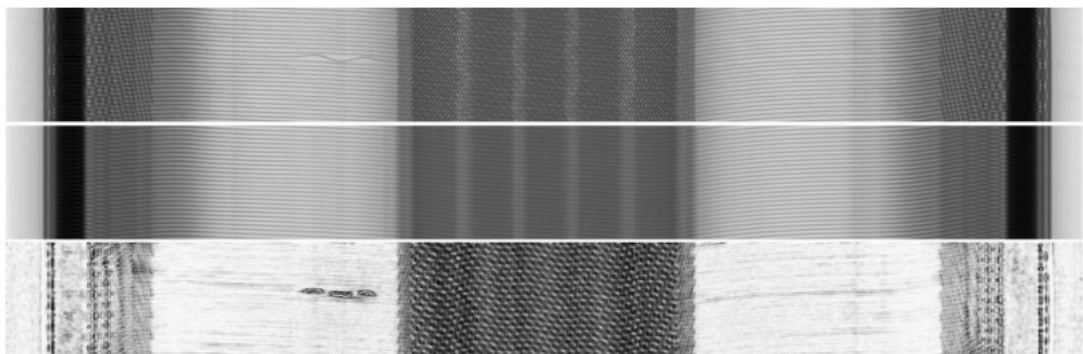

Figure 34 Input image **with** defect (top), reconstructed output image (center), and difference image (bottom) [21]

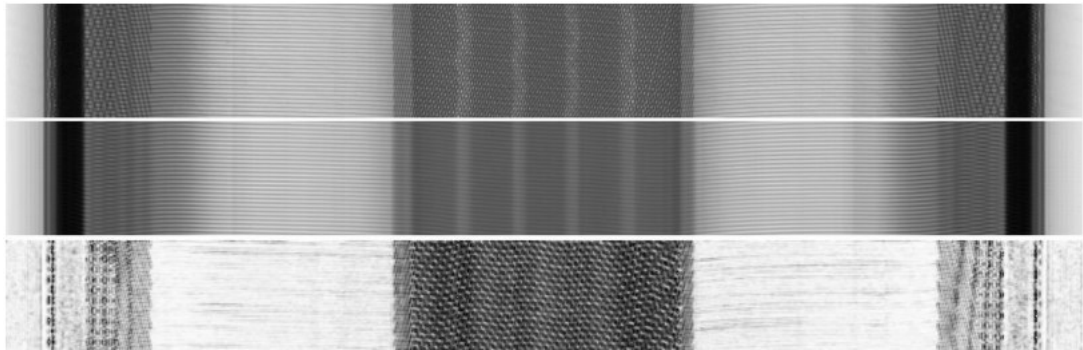

Figure 35 Input image **without** defect (top), reconstructed output image (center), and difference image (bottom) [21]

Further, **Figure 34** and **Figure 35** illustrate how the reconstructed output images differ between defective and defect-free segments. The reconstructed image often appears blurry, but the difference image reveals the location of the defect. The task of the autoencoder is not to reconstruct the input image with high accuracy but to differentiate between defective and defect-free segments as much as possible. [21]

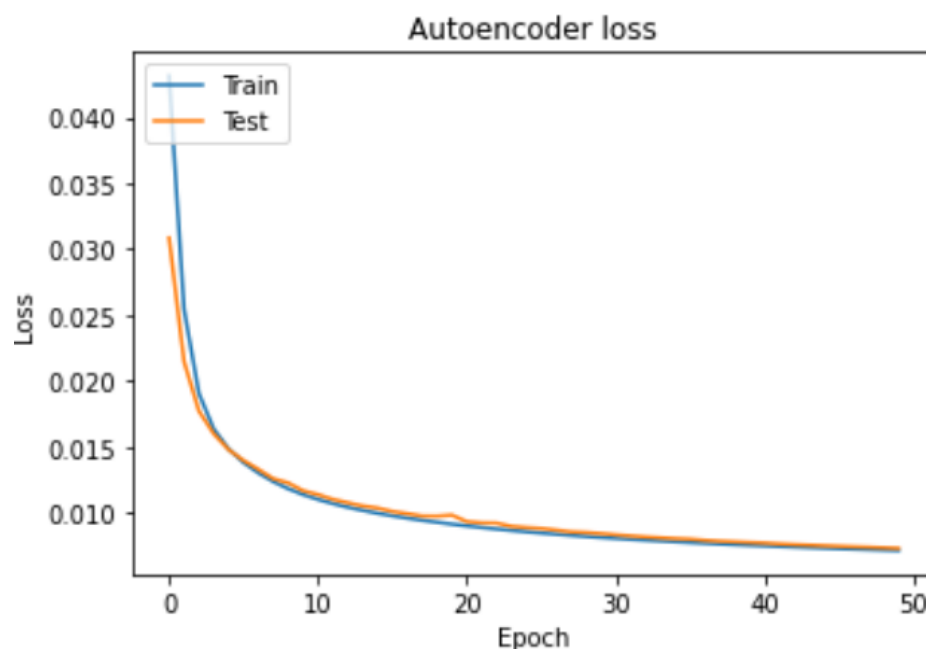

Figure 36 Training and testing errors of the autoencoder architecture [21]

Finally, to evaluate the performance of the best autoencoder architecture, the training and testing errors are plotted over 50 training epochs. This shows how the error decreases as the

architecture learns and provides insight into the training process without using additional normalization techniques. [21]

4.1.8 Possibility for converting an Autoencoder into a CNN for Defect Classification

Following the subdivision of X-labeled X-ray images into segments based on error code, the selected autoencoder architecture categorizes them into defective and defect-free segments using the threshold defined earlier. The manual review ensures that the data set of defective segments contains no defect-free segments and eliminates anomalies that don't represent defects, such as splice markers. The result is a data set with only defective segments, sorted by defect code. This "defect set" is used to train a Convolutional Neural Network (*CNN*) based on the autoencoder's encoder, with all encoder layer parameters frozen to remain unchanged during training. A dense layer is added at the end of the frozen layers, forming the CNN. To train and validate the CNN, the defect set is split into a training set and a validation set, with the training set comprising 90% of the data and the validation set comprising 10%. The sorting is random within each defect class to ensure a representative distribution. [21]

The classification accuracy of the CNN is assessed using various methods, but the evaluation is limited by the uneven distribution of image segments across defect classes. Given the small number of segments for some defects, achieving a uniformly distributed training and validation set is challenging, resulting in potential inaccuracies in the evaluation. However, increasing the number of data segments as they become available can improve accuracy. After the addition of a dense layer with 12 neurons and a softmax activation function to the encoder, the CNN's accuracy is calculated using the validation set. The training set for classification contains 742 image segments, while the validation set contains 86. Given the large number of classes and the varying distribution of images, similar defect types are grouped into a single class, resulting in 12 classes used for classification—11 defect classes and one for splice markers. [21]

The CNN achieved an accuracy of approximately 78%, with 67 out of 86 defects correctly classified. This is a promising result, especially considering the limited number of images for some defect classes and the variability among defects. To improve accuracy, more image data and further refinements to the training process are needed. [21]

		Actual class											
Defect class		1	2	3	4	5	6	7	8	9	10	11	12
Predicted class	1	4											
	2		14			3					1		1
	3			0									
	4				0								
	5		1	1		9			3				1
	6						1						
	7		1					1					
	8				1				1	2			
	9		2							2			1
	10									1	5		
	11											24	
	12												6
Total images per class		4	18	1	1	12	1	1	4	5	6	24	9
Accuracy per class		100 %	78 %	0 %	0 %	75 %	100 %	100 %	25 %	40 %	83 %	100 %	67 %

Figure 37 Matching between predicted and actual defect classes. [21]

Figure 37, a confusion matrix, illustrates the frequency of correct matches between predicted and actual defect classes. The green diagonal represents the correct classifications. The matrix shows that most defects were correctly assigned, but incorrect assignments occurred in classes with fewer data points. Classes with a larger number of images, such as Class 11, had a higher accuracy rate, with all 24 segments correctly assigned in the validation set. This indicates that having more training data leads to better classification accuracy. [21]

Overall, to increase the reliability of the classification, more labeled defective X-ray images are required, which would allow for more accurate and representative evaluation. Further iterations of training and validation can help refine the CNN's accuracy. [21]

4.2 Improvement

This chapter explores the current state and improves the application of artificial intelligence in detecting anomalies of tire X-ray images, beginning with a baseline process that employs a pre-trained AI model to analyze and compare image segments using the *Structural Similarity Index method*. It then progresses to an enhanced approach with a new *compare()* function for detailed pixel-wise comparison, improving the accuracy of anomaly detection. The integration of image-processing libraries like OpenCV is discussed, focusing on optimizing the detection process to balance speed and precision effectively.

4.2.1 Current state

The actual situation is that the code implements anomaly detection in tire X-ray images using artificial intelligence techniques. This process involves loading a pre-trained model, processing the X-ray images, analyzing them for anomalies, and recording the results in a .CSV file. The algorithm starts by loading the AI model, which is then used to analyze the X-ray images of tires. Each image is segmented into smaller parts, which are then analyzed by the model. The analysis results are compared with the original image, and the structural similarity is calculated using the Structural Similarity Index (SSIM) method.

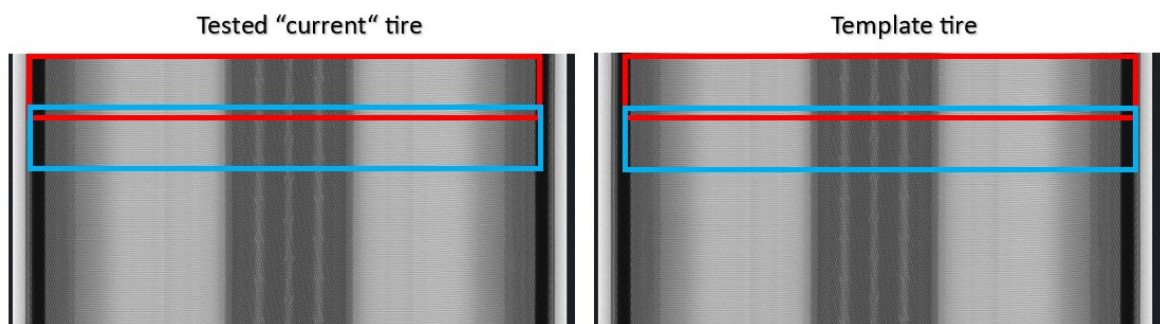

Figure 38 Comparing tested (actual tire) with template tire using small overlapping segments (not dimensionally accurate example)

4.2.2 Enhanced approach - pixel-wise segmentation

The addition of the *compare()* function facilitates pixel-by-pixel comparison of X-ray image segments. This function performs a structural similarity comparison between two image segments, returning a list of similarity scores. The pixel-wise comparison provides more detailed insights into differences between image segments, potentially improving the accuracy of anomaly detection analysis. This helps to lead to more precise identification of anomalies and reduce false positives or false negatives. The advantage of this change lies in enhancing the accuracy of anomaly detection through more granular analysis at the pixel level. This contributes to greater reliability in the anomaly detection system and increases confidence in its results.

The *compare()* function is defined with three parameters: *img_seg1*, *img_seg2*, and an optional *window_size*, which determines the size of the comparison window for pixels. Internal loops iterate over the segments of both images in 5-pixel steps, ensuring overlap with

the previous and following segments. During each iteration, the function crops both images using the current loop position and the *window_size*. Structural similarity is calculated for each crop using the *ssim()* function from *skimage.metrics*. The similarity scores are stored in the *sim_score_list*, which is returned as the output of the function.

This change was implemented by introducing the new *compare()* function and integrating it into the main *find_anomalies()* function. With this modification, detailed pixel-wise comparisons of X-ray image segments are now possible, leading to greater accuracy in anomaly detection and improved system outcomes.

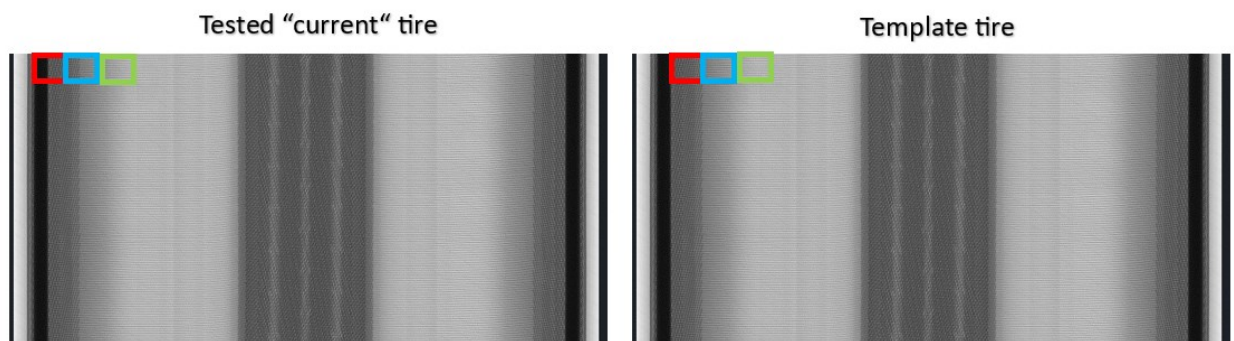

Figure 39 Comparing tested (actual tire) with template tire using small overlapping small pixel segments (not dimensionally accurate example)

4.2.3 Enhanced approach - image-processing libraries, windows size optimization

Optimizing the cycle for anomaly detection in X-ray images can be achieved through various approaches and image-processing libraries like *OpenCV*, *PIL* (Python Imaging Library), and *NumPy*. Another option is to adjust the pixel-wise comparison window size for finer control over detection accuracy.

Here's an outline of these optimization methods, highlighting their advantages and disadvantages:

1. OpenCV (cv2)

Advantages:

- Speed: *OpenCV* is renowned for its fast image processing, especially for tasks like segmentation and comparison.

- **Parallel Processing:** *OpenCV* takes advantage of multi-core processors, improving processing speed.

Disadvantages:

- **Complex API:** *OpenCV's* API can be more complex than other libraries, potentially posing a learning curve for some users.

2. PIL (Python Imaging Library)**Advantages:**

- **Ease of Use:** *PIL* provides a simple interface for image processing, which can simplify development.
- **Wide Format Support:** *PIL* supports a variety of common image formats.

Disadvantages:

- **Slower Processing:** *PIL* may be slower than *OpenCV* when handling large volumes of images.

3. NumPy**Advantages:**

- **Efficient Data Handling:** *NumPy* offers efficient operations with multi-dimensional arrays, speeding up image processing.
- **Easy Integration:** As a widely used library for data processing in Python, *NumPy* integrates well with other libraries.

Disadvantages:

- **Higher Level of Abstraction:** *NumPy* is generally designed for numerical data and might be less flexible than specialized libraries like *OpenCV* and *PIL*.
- **Optimizing Window Size for Pixel-wise Comparison**

Given the need to optimize the anomaly detection cycle in X-ray images for both processing speed and detection accuracy, *OpenCV (cv2)* was selected for this task. The reasons for this choice include:

- **Processing Speed:** *OpenCV* is known for its fast image processing and efficient use of hardware resources, which is essential when handling large volumes of images.
- **Parallel Processing:** *OpenCV* uses parallel processing on multi-core processors, providing a significant speed advantage compared to other libraries.
- **Broad Functionality:** *OpenCV* offers a wide range of image-processing features, including segmentation, filtering, and image comparison, facilitating the implementation of advanced anomaly detection algorithms.

While *PIL (Python Imaging Library)* is user-friendly and has good format support, and NumPy is efficient for data manipulation, *OpenCV's* performance and comprehensive image-processing capabilities make it the ideal choice for our application.

The optimal window size for pixel-wise comparison depends on the specific characteristics of the images and the desired accuracy for anomaly detection. Larger windows provide more information but increase the computational load, while smaller windows could be faster but less accurate. From experimental part was considered to keep the window size.

4.3 Next possibilities with optimization

To improve the efficiency and accuracy of the anomaly detection algorithm in tire X-ray images, consider these key areas for optimization:

a) Threshold Optimization

The choice of threshold significantly affects the results of anomaly detection. Currently, an improperly set threshold can lead to false positives or false negatives.

Proposed Solution: Analyze and optimize the threshold using advanced techniques such as Otsu's method or adaptive thresholding. This should take into account variations in illumination and contrast across different parts of the images, enhancing the accuracy of anomaly identification.

b) Performance Improvement (Evaluation/sec)

Performance, measured as the number of evaluated images per second, can be enhanced through speed optimization and parallelization.

Proposed Solutions:

- **Parallelization:** Leverage multi-core processors to increase processing speed through parallel operations.
- **Algorithm Optimization:** Use more efficient AI architectures and data structures to boost performance.
- **Distributed Processing:** Spread processing across multiple computers or servers for large-scale data handling.
- **Hyperparameter Optimization:** Use automated tools like Optuna or Nevergrad for optimizing AI model hyperparameters. These systems can fine-tune learning rates, network architecture decisions, and other crucial parameters based on systematic trials and evaluation, significantly boosting model efficacy.

c) Additional Optimizations

Optimization can also focus on memory management, pre-processing, and reducing computational load through various methods.

Proposed Solutions:

- **Memory Optimization:** Minimize memory requirements by using efficient memory management and reducing memory-heavy operations.
- **Data Pre-processing:** Apply data pre-processing techniques like noise filtering or image normalization to improve data quality and consistency before analysis.
- **Input Data Optimization:** Reduce image dimensions or pre-process images to lower computational demands.
- **SSIM Algorithm Optimization:** Consider alternative methods for image comparison or refine the existing implementation to enhance performance.

Optimizing the anomaly detection algorithm for tire X-ray images is critical for achieving high accuracy and efficiency. Employing appropriate techniques and methods can significantly enhance detection results and improve algorithm performance, contributing to successful practical implementation.

5 COMPARISON OF IN-HOUSE AI WITH EXISTING SOLUTIONS

Chapter 5 delves into the critical comparison of in-house AI model with existing market solutions for tire inspection. It begins by establishing rigorous criteria for evaluating software features crucial to tire manufacturing quality control, including the localization and classification of anomalies, and the ability to manage diverse tire types efficiently. The chapters provide a thorough examination of various systems, highlighting their capacity to enhance inspection precision, reduce manual labor, and ensure tire safety and compliance with industry standards.

5.1 Feature comparison

This section thoroughly evaluates how each system performs in key areas such as anomaly localization, classification accuracy, and operational flexibility with different tire types, emphasizing their significance in enhancing production efficiency and quality assurance in the industry.

5.1.1 Criteria for software features evaluation/capabilities

Localization of Anomalies

The precise localization of anomalies in tire structures is a crucial aspect of quality control, as it allows for the immediate identification and classification of defects within the tire. This capability enables manufacturing facilities to implement quick corrective measures, thus minimizing the impact on production flow and reducing material waste. Accurate localization helps maintain the structural integrity of tires by ensuring that any anomalies are caught early and addressed before the tires are distributed, thereby safeguarding both consumer safety and manufacturer reputation.

Classification of Anomalies

Classifying anomalies by type and severity is essential for determining the appropriate corrective actions and for maintaining statistical records of tire quality. This process involves distinguishing between critical defects that may affect tire safety and minor imperfections that could be deemed acceptable depending on industry standards. By systematically classifying anomalies, the system provides consistent quality assurance and helps in refining production processes through the analysis of recurring defect patterns.

PCR and TBR Capability

The flexibility to inspect both Passenger Car Radial (PCR) and Truck and Bus Radial (TBR) tires with a single system is highly beneficial for manufacturers that produce multiple types of tires. This capability not only streamlines the inspection process but also optimizes asset utilization within the facility. It ensures that the inspection system can adapt to different sizes and specifications of tires, facilitating a seamless transition between different production batches without the need for extensive reconfiguration or downtime.

Identification of Individual Belts

The identification of individual belts within tires is critical for assessing the assembly quality and ensuring that each belt is aligned and tensioned correctly. This detailed inspection helps prevent potential failures due to belt misalignment or defects, which could lead to catastrophic tire failures on the road. By closely monitoring belt placement and integrity, manufacturers can guarantee that their tires meet rigorous safety and performance standards.

Identification of Individual Areas

Focusing on specific areas within the tire allows for targeted inspections of high-stress or critical zones, such as sidewalls and tread areas. This detailed approach ensures that any defects in these crucial regions are identified and rectified, thereby enhancing the overall durability and safety of the tire. It also facilitates a more granular quality control process, where specific areas can be closely monitored for improvements or changes in production techniques.

Identification of Individual Cords and Angles

Accurately assessing the placement and orientation of cords is essential for evaluating the structural integrity of the tire. Cords are integral components that contribute to the tire's strength and flexibility. Incorrect cord angles or spacing can lead to uneven wear, reduced durability, and safety risks. Detailed examination of cords ensures that they are uniformly distributed and aligned according to design specifications, which is crucial for the tire's performance and the safety of the end users.

Pix-mm Conversion

The Pix-mm Conversion is a critical feature in tire inspection systems, providing a precise correlation between the pixel measurements obtained from X-ray images and their actual sizes in millimeters. This conversion is vital for accurate dimensional checks and quality control, allowing for exact measurements of tire components such as tread depth, sidewall thickness, and internal structures. By quantifying these elements accurately, manufacturers can ensure that each tire adheres to strict specifications and tolerances. The ability to convert pixel measurements to real-world metrics also enhances the system's utility in a production environment by supporting detailed inspections and ensuring that the tires meet regulatory standards as well as customer expectations.

Lower Slip-Through Rate Than Human Operator

Implementing automated inspection systems significantly reduces the likelihood of defects passing through the inspection process unnoticed, compared to inspections conducted by human operators. Automated systems are designed to consistently apply the same criteria and perform checks with a high level of precision, without the variability introduced by human fatigue, subjective judgment, or other human factors. This consistency results in a lower slip-through rate of defects, which means fewer defective tires reach the market, enhancing product reliability and consumer trust. Moreover, reducing human error in tire inspections directly contributes to improved safety outcomes and can potentially decrease the likelihood of costly recalls and reputational damage.

Supplier Independence

The ability of an X-ray inspection system to operate independently of supplier-specific constraints offers significant advantages in terms of flexibility and integration. Being supplier-independent means that the system can be integrated into various production lines without being tied to specific hardware or software provided by one supplier. This independence facilitates easier system updates, expansions, and maintenance, as manufacturers are not restricted to a single supplier's protocols and can choose from a broader range of components that best meet their operational needs. It also empowers manufacturers to negotiate better

terms and prices with multiple suppliers, enhancing operational resilience and reducing the risk of supply chain disruptions.

5.1.2 Benefit Comparison

Description of the benefits of tire X-ray SW inspection systems:

Workload Reduction of Operator and Grader

The implementation of advanced X-ray software systems in tire manufacturing significantly reduces the workload for both groups - operators and graders. These systems are equipped with automated defect recognition software that accurately identifies and classifies defects without human intervention, thus minimizing the need for manual inspection. This automation allows operators and graders to focus on more critical tasks, enhancing their productivity and reducing fatigue. Moreover, the reduction in manual workload decreases the likelihood of human error, contributing to more consistent and reliable quality control.

Detection of Article-specific Defects

Advanced SW X-ray inspection systems are adept at identifying article-specific defects, such as missing belts or belt-specific imperfections, which might not be visible to the naked eye. These systems use high-resolution imaging and precise detection algorithms to scan every tire for unique, article-dependent defects, ensuring that each tire meets the specified quality standards. This capability is crucial for maintaining high levels of customer satisfaction and compliance with safety regulations, as it prevents defective tires from reaching the market.

Classification of Area-specific Defects

X-ray inspection systems not only detect defects but also classify them according to specific areas of the tire, such as the tread, sidewall, or bead. This classification helps in accurately pinpointing the location of defects, and facilitating targeted interventions and remedial actions. By systematically categorizing the defects, the systems provide valuable insights that can be used to refine manufacturing processes and reduce the occurrence of such defects in future production cycles.

Measurement of Cord-distances and Classification of Cord-specific Anomalies

These systems measure the distances between cords and classify anomalies specific to the cord structure, such as crossed or touching cords, which are critical for the structural integrity of the tire. Accurate measurement and classification help in assessing the quality of the internal structure of the tire, ensuring its strength and durability. This is particularly important for high-performance and safety-critical applications where the precise alignment of cords is essential.

Measurement of Anomaly/Defect Size

The ability to measure the size of anomalies or defects is crucial for determining their severity and potential impact on tire performance and safety. X-ray systems provide exact measurements of defect dimensions, allowing manufacturers to make informed decisions about whether a tire can be corrected or must be rejected. This precise measurement capability ensures that only tires that meet all quality criteria are approved for sale and use.

Future-proof Solution, Implementation of Conti-specific Requirements Possible

X-ray inspection systems are designed to be future-proof, accommodating upgrades and integrations with minimal adjustments. This adaptability makes it possible to implement Continental-specific requirements, allowing for customization according to the company's unique needs and standards. Such flexibility ensures that the systems can evolve in response to new technologies or changing industry standards, thereby protecting the investment over the long term.

5.1.3 Table with software solutions features in X-ray

Table 2 Comparing some of the chosen available SW solutions for X-ray inspection and their features

Topic	Own system	MicroPoise ADR	Yxlon TireAxis	CyxPlus CyXpert
Localization of anomalies	y	y	y	y
Classification of anomalies	n	y	y	y
PCR and TBR capability	y	y	y	n
Identification of individual belts	(n)	y	y	y
Identification of individual areas	n	y	y	y
Identification of individual cords and angles	n	y	y	y
Pix-mm conversion	(y)	y	y	y
Lower slip-through-rate than human operator	y	y	y	n
Supplier independant	y	n	n	n

1. Own system

In the present stage of system development, it can be affirmed that the system is adept at localizing anomalies and indicating the areas where these anomalies occur. However, classification issues are more problematic, as the current in-house model fails to classify individual imperfections – development/programming is not done on the currently used AI model. There exists a similarly programmed model at Continental that could be integrated into the development phase to improve classification capabilities, a potential demonstrated in the discussion of the internal model (4.1.8). In terms of PCR and TBR capability, the model is trained on correct images, which does not encompass the problems associated with using it for both technologies. The identification of individual belts and areas, along with the cords and angles, is problematic with the current model. As for pixel-mm conversion, although Continental has developments in another project, they are not yet available for full functionality in the current project. Nevertheless, one of the model's strengths is its independence—all developmental oversight is conducted by the Continental team, and it also has a lower slip-through rate compared to operators without any assistance programs.

2. Micropoise ADR

In the case of Micropoise and its allied company Jo-Vision — which provides all development and care of ADR software, the software is adept not only at localizing anomalies but also at classifying them, effectively identifying the specific type of defect. This capability is attributed to the fact that Jo-Vision utilizes multiple AI models within the program, unlike our development which relies on a single model. Micropoise runs approximately four different AI models, each serving distinct purposes; one for anomaly detection, another for classification, and so on. The software also handles individual cords and angles, as well as the detection of different belts and areas. Thanks to the pixel-to-millimeter functionality, it enables highly precise calculations of object sizes in X-ray images across all layers. Additionally, Micropoise is one of the few in the market to offer the possibility of full automation of the system, using only a type of inspector—a grader—to evaluate X-ray images flagged as defective or suspicious. The challenge of such software is not necessarily whether the grader will have more or less work (reduce workload)—which is indeed an important parameter—but the most critical requirement is that no imperfect tire escapes detection. The system must, therefore, possess a 100% defect detection capability.

3. Yxlon TireAxis

Regarding the software provided by Yxlon, it can be noted that its capabilities are quite similar to those of the software from Micropoise. As indicated in **Table 2**, the Yxlon system can detect and classify various defects and also supports pixel-to-millimeter (px-mm) technology, along with handling belts, areas, and angles. However, a significant limitation of Yxlon software is the lack of substantial ongoing development. General advancements and necessary enhancements in the software are extremely challenging, and perhaps even impossible, due to the company's strategic direction. Although a certain level of automation is currently available, matching the operational level provided by Micropoise, there is no further possibility to integrate advanced artificial intelligence capabilities—which are essential in the X-ray industry and currently, there are no alternatives on the market to replace such functionality.

4. CyXplus

Similarly to the previously mentioned companies, is a significant player in the X-ray market. Their market strategy has undergone several changes, and currently, their software focuses predominantly on PCR (Passenger Car Radial) tires, with an emerging trend towards TBR (Truck and Bus Radial) tires. Given the importance of TBR tire inspection, the incomplete functionality in this area could prove to be a decisive factor for the company. According to available knowledge, their detection software is capable of identifying individual defects and also offers classification capabilities. However, the pixel-to-millimeter (px-mm) technology and calibration accuracy may not be as precise as those offered by other companies. Furthermore, the capability for full automation is not currently fully available in their development; instead, it appears more as an adjunct to operator assistance through supplementary software.

5.2 Conclusion

This chapter synthesizes the evaluation of different X-ray inspection systems discussed previously, concluding that the focus of further development and research will be centered on the internal system and the ADR software provided by Micropoise. This decision is driven by several critical factors that differentiate these systems from competitors like Yxlon and CyXplus, particularly in terms of functionality, ongoing development, and update capabilities.

The internal system at Continental shows promising capabilities in localizing anomalies and pinpointing problematic areas within tire structures. However, it faces challenges in classification due to its reliance on a singular AI model and lacks the broader developmental support seen in more advanced systems. Notwithstanding, it boasts significant strengths such as operational independence and a lower error pass-through rate as an operator, making it a valuable asset for in-depth study and enhancement.

On the other hand, Micropoise ADR software, supported by Jo-Vision, stands out due to its comprehensive functionality and the integration of multiple AI models that facilitate not only the detection but also the precise classification of tire defects. The software's ability to handle complex measurements with its pixel-to-millimeter accuracy and to offer full automation with minimal human oversight positions it as a leader in the field with available features. The potential for a 100% defect detection capability underscores its critical role in ensuring quality and safety in tire manufacturing.

In contrast, Yxlon and CyXplus, while comparable in some capabilities, fall short primarily due to their limited ongoing development and the challenges associated with enhancing their existing technologies to meet current and future demands. Yxlon strategic limitations and CyXplus's focus on a niche market segment without fully developed automation capabilities restrict their suitability for comprehensive academic exploration and application.

Therefore, the master thesis will concentrate on exploring and enhancing the internal system and ADR software from Micropoise. This focus is justified by their superior technological foundations, the breadth of capabilities, especially in anomaly detection and classification, and the ongoing commitment to development and updates. These attributes are essential for advancing the state of the art in tire inspection technology, ensuring that no defects slip through the inspection process, thereby enhancing both the reliability and safety of tire products in the market.

6 DETAILED COST-BENEFIT ANALYSIS

This chapter undertakes a comprehensive examination of the economic implications associated with the implementation of automated X-ray inspection systems. By assessing both the direct and indirect costs, potential benefits, and accompanying risks of various deployment scenarios, this analysis aims to provide a robust framework for informed decision-making.

6.1 Assumptions and facts (figures) – costs

This section breaks down the investments required for material handling adaptations which are essential for facilitating the smooth operation of automated systems. The examination extends to estimating the expenses tied to integrating these systems within existing infrastructures, which is critical for planning and budgeting.

6.1.1 Common costs

When discussing the financial aspects of implementing such a system, multiple factors must be considered. The introduction of full automation into an existing project entails significant investments in various areas. One of the critical elements is the adaptation of the material handling system, specifically the conveyor systems, which will require a buffer zone for tires awaiting assessment by the grader. Modifications to the layout of X-ray measuring stations may also be necessary.

Moreover, integrating such software into an existing X-ray machine setup involves considerable challenges. This includes PLC (Programmable Logic Controller) adaptations to ensure seamless interaction with the IT interface, and the incorporation of the new software into an already complex existing infrastructure. These modifications necessitate both physical and technical labor to implement the changes effectively in a real-world manufacturing environment.

While the costs associated with these adaptations are somewhat consistent across different solutions—whether internal or those available in the market—the specific estimated costs for implementing these changes in a production plant like Otrokovice can be outlined as follows:

- Integration/Adaptation Costs: This covers the cost of modifying existing PLC code, and establishing IT communications with the internal network, or conveyor systems, amounting to approximately **50 000 €.**

- Conveyor System Modifications/Buffer Creation: The cost of altering the conveyor systems to create a buffer for tires that need to be graded is estimated at around **100 000 €.**
- Technician Labor Costs (Service Cost): The expenses for the technical labor required to implement these changes are estimated **50 000 €.**

These estimates provide a preliminary financial framework for the implementation of a fully automated X-ray inspection system. It is essential to factor in these costs early in the project planning phase to ensure budget adequacy and feasibility. Additionally, considering the long-term benefits such as increased efficiency, reduced error rates, and enhanced quality control, these initial investments may be justified. Furthermore, continuous development and updates to the system can bring about operational efficiencies that reduce the overall lifecycle costs associated with maintaining such advanced diagnostic equipment.

6.1.2 Individual cost dependent on the selected system

The implementation of advanced X-ray inspection systems, whether in-house or through a provider for example Micropoise, involves various costs and operational adjustments. Here, we delve into the financial and operational implications of these two distinct approaches, focusing on their cost structures and deployment metrics across a global scale with 19 machines operating over 4 shifts.

1. In-house AI Solution

The in-house AI solution involves a team of four developers with an average cost per developer, including travel and related expenses, totaling 130 000 € annually. The initial implementation cost for software on a single machine is estimated at 10 000 € with an additional 5 000 € per machine for software implementation. This solution requires significant in-house support, costing 100 000 € yearly for 24/7 assistance. Interestingly, while the number of operators needed is halved, the requirement for graders remains unchanged at 100%. The development time for the in-house algorithm is 1,5 years, with a planned rollout in the third year.

Financial Breakdown:

- Development Costs: 4 developers x 130 000 € = 520 000 € annually
- Initial Setup: 10 000 € for one machine + 5 000 € per additional machine
- Ongoing Support: 100 000 € for 24/7 in-house support

Operational Impact: Reduced operator requirement by 50% does not decrease grader needs, suggesting a focus on maintaining quality control while optimizing labor costs.

2) Micropoise (MP) solution:

Micropoise offers a more streamlined time-to-market, with no initial investment or development time required and a rollout starting in the first year. The cost of the first installation of the software is estimated to be up to 300 000 € per machine, which also applies to additional machines. While MP does not require ongoing in-house support costs, it incurs 50 000 € annually in additional costs for services, extensions, and operational hours. Notably, the MP solution eliminates the need for additional operators and reduces the grader requirement by 50%.

Financial Breakdown:

- Software Costs: estimated from internet as €300,000 per machine
- Yearly Additional Costs: €50,000 for extensions and services

Operational Impact:

Elimination of operator roles and reduction of grader involvement by 50% significantly reduce labor costs and potentially increase process efficiency.

6.1.3 Comparative Analysis:

Comparing these two systems, the in-house solution appears to be more labor-intensive and costly in terms of development and ongoing support, but it allows for a tailored approach that might better suit specific operational nuances. On the other hand, the Micropoise solution, while expensive per machine, offers a quicker deployment and less labor dependence, potentially providing a faster return on investment and lower long-term operational costs.

The choice between these systems should consider not only the direct costs but also the strategic implications on workforce management and long-term scalability. Each organization's specific needs, existing infrastructure compatibility, and strategic goals will heavily influence the decision-making process.

6.2 Implementation scenarios

This section offers an in-depth exploration of the current implementation of X-ray inspection systems within an industrial context and also possible implementation scenarios for potential full-automatic inspection on X-ray devices.

6.2.1 Current X-ray situation

The Otrokovice plant provides a good example of the current implementation of X-ray inspection systems in an industrial setting. Here, three X-ray devices are actively utilized, each operated by a technician who has access to specialized support software. This software plays a crucial role in defect detection within tires, significantly aiding operators in identifying potential issues.

Operational Workflow:

Each operator is equipped with support software that enhances the detection of defects in the tires. This auxiliary software, not universally available across all global solutions, provides a critical advantage in operational efficiency. In some regions, similar operations may proceed without such software support, potentially affecting the consistency and effectiveness of defect detection.

Upon detecting a defect, the operator uses both the X-ray analysis and the recommendations from the support software to make an informed decision about the tire's fate:

- **Release for Market:** If the tire meets all quality standards.
- **Send to Grader:** For a more thorough assessment to determine if the tire can be repaired or must be scrapped.

Figure 40 visually represents this process, illustrating the flow from inspection through decision-making, highlighting the interplay between human oversight and software assistance.

Analysis and Risks

This system's reliance on human operators supported by diagnostic software underscores a hybrid approach to quality control, balancing technological assistance with human expertise. However, this setup also raises several points for consideration in the context of scaling or upgrading inspection systems:

- **Efficiency and Reliability:** The support software enhances the efficiency of defect detection but also places significant responsibility on operators for final quality assurance decisions. This could vary the consistency of outcomes based on individual operator expertise and experience.
- **Scalability:** The current setup with three devices and corresponding operators may pose scalability challenges. Increasing production demands may necessitate additional machines and operators unless more automated solutions are considered.
- **Cost Implications:** While the support software reduces the likelihood of defects passing undetected, the costs associated with human operators and potential errors could be significant. Automated systems might offer long-term savings through reduced labor costs and lower error rates.
- **Adoption of Fully Automated Systems:** Considering the advancements in artificial intelligence and machine learning, transitioning to a more automated system could minimize human error and increase throughput. This shift would require a careful cost-benefit analysis, considering both the initial investment in technology and the reduction in labor costs over time.

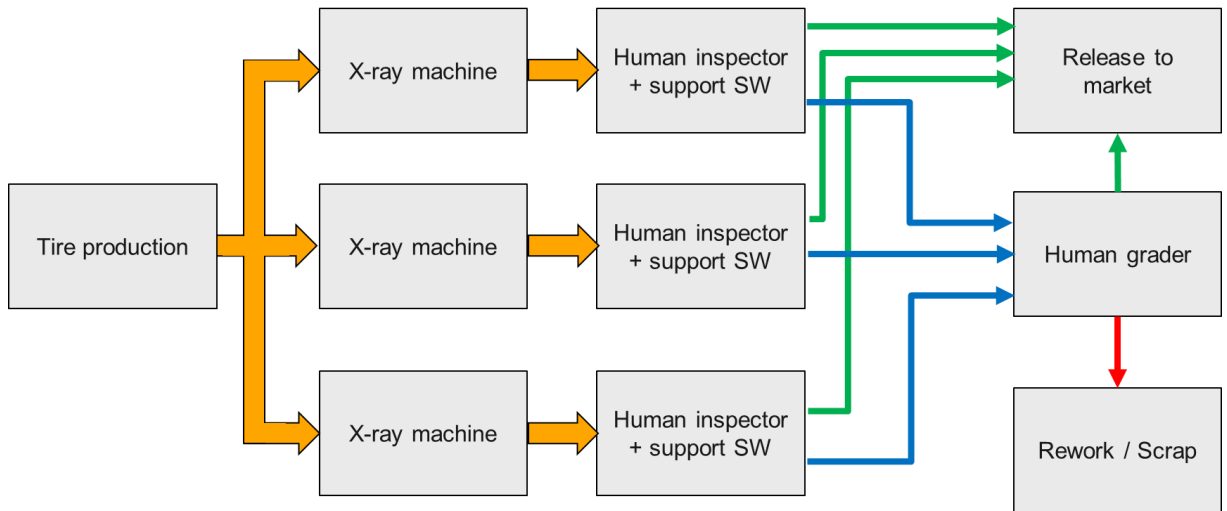

Figure 40 Current X-ray image analyze process

6.2.2 Fully automatic scenario from market

In the realm of industrial X-ray inspection, a significant shift is observable with the advent of fully automated systems utilizing AI and precise pixel-to-millimeter (px-mm) conversions. Considering the Otrokovice facility as a case study, where three X-ray devices were (are) previously operated manually, we now explore a scenario where these are controlled by a computerized system, which can be implemented either through server-based solutions or directly on-site physical systems.

Operational Details:

In this fully automated setup, the software autonomously performs the inspection tasks. It leverages trained AI algorithms and px-mm conversion data to assess each tire. The decision-making process is entirely data-driven, where the AI evaluates the integrity of the tire based on predefined quality metrics and decides:

- **Release for Market:** If the tire meets the quality standards according to the learned data.
- **Send to Grader:** For further evaluation to determine if the tire can be repaired, should be released to the market, or needs to be scrapped.

Figure 41 illustrates this automated process, showing the flow of operations from the initial X-ray scanning to the final decision-making phase, highlighting the reduced need for human intervention.

Analysis:

- **Efficiency Gains:** The transition to full automation is expected to enhance efficiency significantly. AI-driven systems can process a higher volume of tires at a faster rate than human operators, reducing bottlenecks and increasing throughput.
- **Accuracy and Reliability:** AI systems, with their capability to learn and adapt, can potentially offer higher accuracy in defect detection. The use of px-mm conversions allows for precise measurements and assessments, minimizing the probability of human error.
- **Cost-Effectiveness:** Initially, setting up a fully automated system might involve substantial investment in hardware and software development. However, the long-term savings from reduced labor costs and decreased error rates could justify the upfront expenditure.
- **Scalability and Flexibility:** Automated systems are highly scalable, allowing for easy expansion or modification based on production needs without significant additional costs. They can also adapt more swiftly to changes in production types or quality standards.
- **Reduced Human Dependency:** By reducing the reliance on human graders and operators, the system decreases the variability introduced by human judgment and fatigue. However, this also implies a shift in workforce requirements, with a potential reduction in traditional roles and an increase in more specialized IT and maintenance roles.

Risks:

- **Technological Dependence:** Heavy reliance on AI and automated systems increases vulnerability to software malfunctions or failures. Any bugs or system errors could lead to significant disruptions in production and potential quality control issues.

- **Initial Cost and ROI:** The initial investment in fully automated systems can be substantial. Organizations must assess the return on investment, considering the cost of technology acquisition, integration, and potential downtime during the transition phase.
- **Loss of Human Expertise:** By replacing human operators with AI, there is a risk of losing valuable human insights that come from years of experience. AI may not yet fully replicate the nuanced judgment of experienced graders, particularly in complex or borderline cases.
- **Cybersecurity Risks:** As reliance on digital systems increases, so does the vulnerability to cyber-attacks. Ensuring the security of AI systems and data integrity becomes paramount to prevent malicious interventions that could affect production quality.
- **Regulatory and Compliance Issues:** Compliance with industry standards and regulations might be challenging as these systems need to be continuously updated to meet evolving norms. Additionally, certifying AI decisions for critical safety components like tires requires robust validation protocols.
- **Adaptability and Scalability:** While AI systems are highly scalable, their adaptability to unexpected changes in production or new types of tire defects could be limited. AI models require continuous training and updates to handle new scenarios effectively.
- **Ethical and Employment Concerns:** Shifting to full automation could lead to significant workforce reductions, raising ethical questions and potential backlash. Managing this transition sensitively and ethically is crucial to maintaining social responsibility.

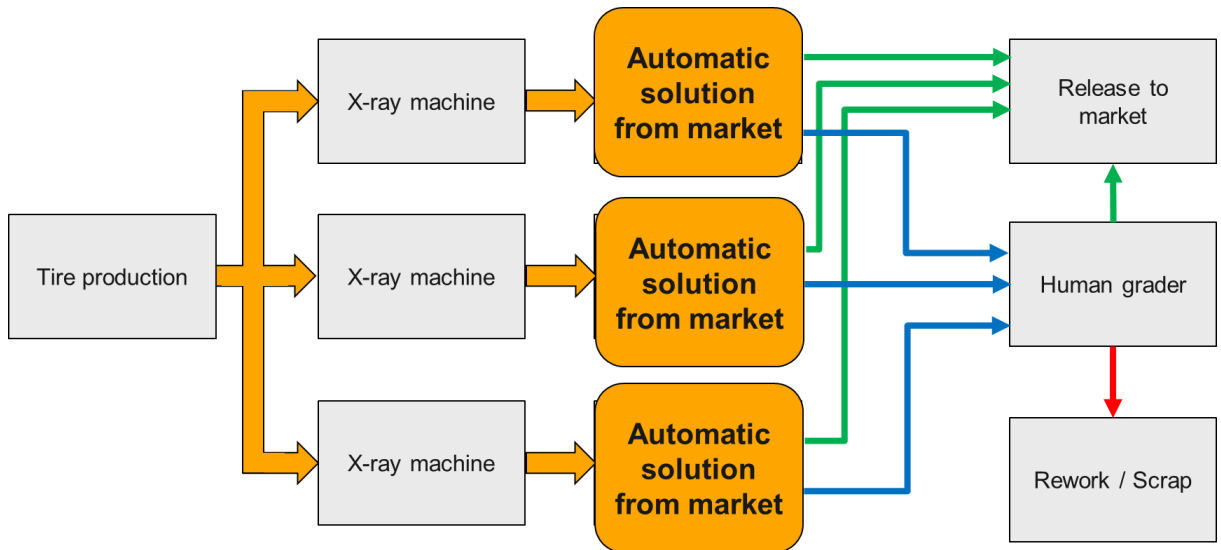

Figure 41 Scenario - Fully automatic solution from the market

6.2.3 In-house AI scenario

The in-house AI scenario presents a strategic shift towards full automation using a proprietary artificial intelligence solution and pixel-to-millimeter conversions. This scenario is highly regarded for its potential but is contingent on the successful completion of the ongoing development of in-house technologies, including the integration of px-mm calculations, which are not yet fully operational.

Operational Workflow:

In this setup, the three X-ray devices previously managed by operators are now operated by computers, which can be either server-based or physically present at the facility. The in-house AI software autonomously processes each tire, making decisions based on a database of trained data, artificial intelligence algorithms, and available px-mm conversions. The AI determines whether a tire is suitable for the market, needs further evaluation by a grader, or should be scrapped. This streamlined decision-making process is illustrated in **Figure 42**

Analysis:

- **Customization and Control:** An in-house AI system offers tailored solutions specific to the company's requirements and allows for greater control over the technology's functionality and improvements.

- **Data Security:** Keeping the AI development and operations in-house enhances data security, as sensitive information does not need to be shared with external vendors.
- **Integration with Existing Systems:** The AI can be more seamlessly integrated with existing IT infrastructure and adapted to the specific operational nuances of the company.
- **Cost Efficiency in the Long Term:** Although initial development costs might be high, over time, the in-house solution can become cost-efficient due to savings on licensing fees and external service costs.

Risks:

- **Resource Intensive:** Developing an AI solution in-house requires significant investment in skilled personnel, research and development, and ongoing training to maintain the system's efficacy.
- **Development Time:** The timeline to develop a fully functional in-house AI system can be lengthy, risking delays in achieving operational efficiency and market responsiveness.
- **Scalability:** Scaling an in-house system to handle increased production or additional facilities might require substantial additional investment in both hardware and software enhancements.
- **Technical Expertise:** Maintaining an in-house team with sufficient AI and machine learning expertise is crucial, which can be challenging given the competitive market for such skills.
- **Risk of Obsolescence:** Technology evolves rapidly, and in-house systems require continuous updates and upgrades to stay relevant, which can be a significant ongoing commitment.

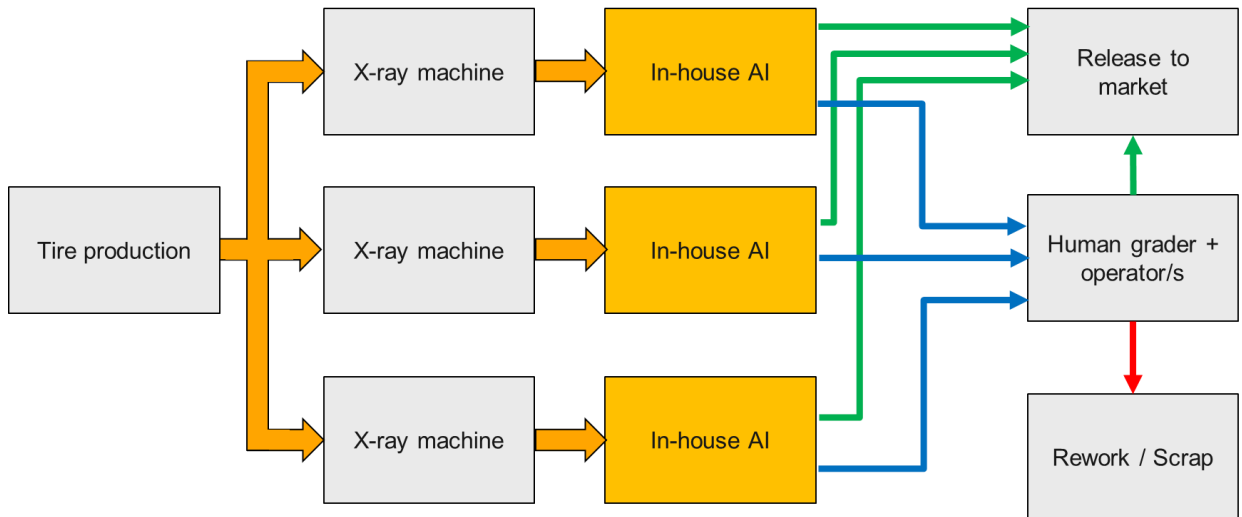

Figure 42 Scenario - Fully automatic in-house AI solution

6.2.4 Combined scenario - In-house AI + solution from market

The combined scenario merges the strengths of both in-house AI development and external market solutions. This scenario is implemented in facilities with three X-ray machines now operated by computers running an in-house AI model, which can be managed either server-based or physically on-site.

Operational Workflow:

In this setup, the in-house AI initially processes each tire based on trained data sets to determine if the tire meets the quality standards for market release. When the in-house AI encounters complex cases or anomalies that do not match its training data, it triggers the integration of an external solution. This might involve purchasing a single license from an external provider, which then assesses and measures the tire using advanced px-mm technology and other functionalities not available in the in-house system. After this enhanced evaluation, the tire may be forwarded to a grader for a thorough review to decide if it can be repaired, released to the market, or needs to be scrapped. This process is visually represented in **Figure 43**.

Analysis:

- **Enhanced Accuracy and Capabilities:** By integrating both in-house and external technologies, the system can handle a wider variety of situations and provide more accurate assessments, especially in complex or ambiguous cases.
- **Cost-Effective Licensing:** The need to purchase only a single license for advanced capabilities can be more cost-effective than fully transitioning to an external system, maintaining budget control while enhancing functionality.
- **Customization and Flexibility:** The in-house system can be tailored to meet most of the operational needs while the external system can be used to address specific challenges or limitations of the in-house AI.
- **Risk Management:** This approach reduces the dependency on a single technology or provider, spreading the risk and potentially increasing system resilience.

Risks:

- **Integration Complexity:** Combining in-house and external systems requires robust integration, which can be technically complex and might lead to potential compatibility issues.
- **Operational Overhead:** Managing two systems simultaneously can increase the operational complexity and require more sophisticated training and support structures.
- **Dependence on External Providers:** While the dependency is reduced, there is still a significant reliance on external technology for critical assessments, which can pose challenges in terms of data security and operational continuity.
- **Cost Management:** Although the licensing may be cost-effective, ongoing costs associated with updates, maintenance, and potential scaling need careful management.
- **Performance Monitoring:** The effectiveness of the combined system must be continuously monitored to ensure that the integration delivers the intended results without degrading the overall system performance.

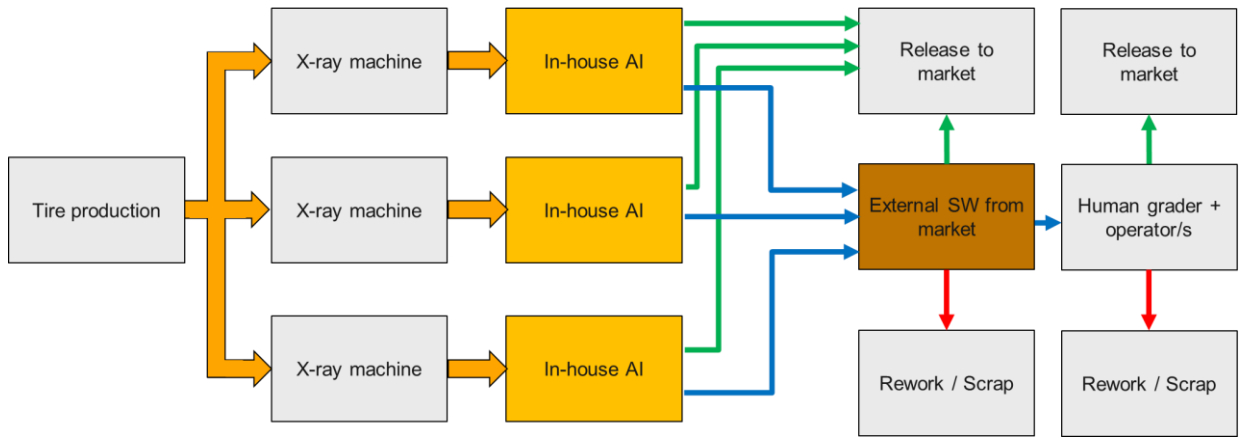

Figure 43 Scenario - In-house solution with external software support

6.3 Cost evaluation

Table 3 Cost-benefit calculation for In-house and Micropoise fully automatic solution (without common costs) for all Continental plants roll-out

Year	Costs in-house	Savings in-house	Total in-house	Costs MP	Savings MP	Total MP
0	0 €	0	0	400 000 €	280 200 €	-119 800 €
1	520 000 €	0	-520 000 €	6 050 000 €	5 639 200 €	-530 600 €
2	420 000 €	46 700 €	-893 300 €	50 000 €	5 639 200 €	5 058 600 €
3	795 000 €	1 774 600 €	86 300 €	50 000 €	5 639 200 €	10 647 800 €
4	100 000 €	1 774 600 €	1 760 900 €	50 000 €	5 639 200 €	16 237 000 €
5	100 000 €	1 774 600 €	3 435 500 €	50 000 €	5 639 200 €	21 826 200 €
6	100 000 €	1 774 600 €	5 110 100 €	50 000 €	5 639 200 €	27 415 400 €
7	100 000 €	1 774 600 €	6 784 700 €	50 000 €	5 639 200 €	33 004 600 €
8	100 000 €	1 774 600 €	8 459 300 €	50 000 €	5 639 200 €	38 593 800 €
9	100 000 €	1 774 600 €	10 133 900 €	50 000 €	5 639 200 €	44 183 000 €
10	100 000 €	1 774 600 €	11 808 500 €	50 000 €	5 639 200 €	49 772 200 €

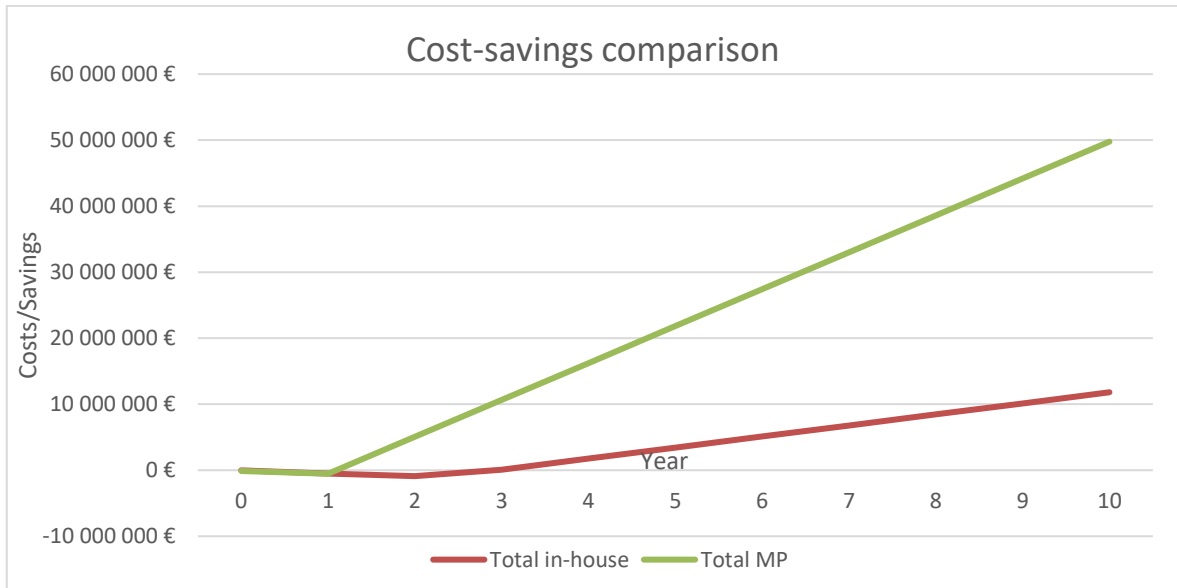

Figure 44 Cost-saving comparison between In-house solution and Micropoise SW solution thru all plants on the for all Continental plants roll-out

The cost evaluation presented in this section compares the financial implications of implementing fully automated X-ray inspection systems using an In-house AI solution versus a Micropoise (MP) software solution across all Continental plants. This analysis is focused on direct costs associated with each solution, their respective savings, and the cumulative financial impact over a ten-year rollout period.

Table 3 illustrates a year-by-year breakdown of costs, savings, and net totals for both the In-house and Micropoise solutions, excluding common costs such as infrastructure changes that would be necessary regardless of the chosen solution. The initial and ongoing costs, alongside the savings generated through improved efficiency and reduced labor costs, are summarized. This financial projection helps in understanding the long-term economic outcomes of each strategy.

Cost Structure:

- **In-house Costs:** Begin at 520 000 € in Year 1, primarily due to development and implementation expenses, then stabilize at 100 000 € annually from Year 4 onwards, reflecting maintenance and minor updates.

- **MP Costs:** Start with a higher initial investment of 400 000 € in Year 0 and 6 050 000 € in Year 1, due to licensing fees and the cost of integrating the solution across multiple facilities. Ongoing costs remain low at 50 000 € annually for maintenance and update requirements.

Savings:

- **In-house Savings:** These start to accrue significantly from Year 3, reaching up to 1 774 600 € annually, due to the reduction in operational costs and the elimination of manual inspection processes.
- **MP Savings:** Demonstrates a robust start with 280 200 € in Year 0, escalating to 5 639 200 € annually from Year 1 onwards, suggesting substantial operational efficiencies and possibly a reduction in quality-related losses or rework.

Total Net Impact:

- **In-house:** Shows a net negative impact in the first two years, breaking even in Year 3, and then showing increasing net positive totals, culminating in **11 808 500 €** by Year 10.
- **MP:** Displays a significant initial positive impact, which consistently grows, reaching **49 772 200 €** by Year 10.

Chyba! Nenalezen zdroj odkazů. graphically represents the cost-saving comparison between the In-house and Micropoise solutions, illustrating a clear trend: while the In-house solution takes longer to become financially beneficial, it steadily increases in net savings after the initial investment period. In contrast, the MP solution offers immediate and substantial financial benefits from the first year, stabilizing at a high level of annual savings thereafter.

6.4 Decision analysis

This chapter outlines two key methodologies employed to quantify and compare the efficacy of different solutions based on a range of predefined criteria. Each method is used to derive insights that aid in making informed decisions regarding the selection of an optimal strategy or solution.

6.4.1 Evaluation criteria and rating - Pairwise comparison

Table 4 represents a multi-criteria decision matrix utilized to evaluate nine different options across various predefined criteria. Each option represents a possible choice or alternative in a decision-making scenario.

Criteria:

- **Initial Costs (first machine):** This criterion evaluates the upfront investment required for the first machine.
- **Single Supplier Dependency:** Assesses the risk or dependency on a single supplier for parts or services.
- **Flexibility/Scalability/Further Extensions Possible:** Considers the ability of the system to be upgraded or expanded.
- **Service/Maintenance/Support Structures Availability, Experience Needed to Use Software:** Focuses on the availability of service and support and the ease of use of the system.
- **Operational Costs:** Pertains to the ongoing expenses associated with the operation of the machine.
- **Product Scope/Content/Quality Improvements:** Evaluate the potential for product improvements and quality enhancements.
- **Time to Market:** Considers how quickly the product can be introduced to the market.
- **Standard Components Used:** Assesses the degree to which standard components are utilized in the system.
- **Level of Automation:** Measures the automation level of the machine, which impacts efficiency and labor costs.

Scoring: Each criterion is scored for each option, with some cells marked with an *x*, indicating the primary focus or characteristic of that option regarding the criterion. The scores range from 2 to 9, where a higher number might indicate better performance or higher importance, depending on the specific criterion.

Total and Weight: At the bottom of the matrix, *Total* scores sum the ratings for each option across all criteria. *Weight* assigns a relative importance to each option, calculated as a

proportion of the total score across all options. This decision matrix is a fundamental example of quantitative decision-making tools in management and engineering. It facilitates a structured approach to decision-making, where multiple criteria are considered simultaneously to determine the best option among several possible alternatives. This method is particularly useful in fields like operations research, project management, and strategic planning.

When applying such a matrix, it is crucial to ensure that the criteria selected are relevant to the decision context and that the scoring and weighting are accurately reflecting the priorities of the decision-making entity. Sensitivity analysis might also be performed to see how changes in weights or scores affect the preferred option, ensuring robustness in decision-making.

Table 4 Pairwise comparison

Criteria	1	2	3	4	5	6	7	8	9
1. Initial costs (first machine)	x								
2. Single supplier dependency	2	x							
3. Flexibility/Scalability/Further extensions possible	3	3	x						
4. Service/maintenance/support structures availability, experience needed to use software	4	4	4	x					
5. Operational costs	5	5	5	5	x				
6. Product scope/content/quality improvements	6	6	6	6	5	x			
7. Time to market	7	7	3	4	5	6	x		
8. Standard components used	8	2	3	4	5	6	7	x	
9. Level of automation	9	9	9	4	5	6	9	9	x
Total	0	2	4	6	8	7	3	1	5
Weight	0,00	0,06	0,11	0,17	0,22	0,19	0,08	0,03	0,14

6.4.2 Evaluation – criteria analysis

After conducting a pairwise comparison, criteria analysis (**Table 5**) serves as a crucial step in decision-making, particularly when multiple alternatives must be evaluated against a set of performance indicators or criteria. This analysis involves a comprehensive review and scoring of each alternative against established criteria while considering the specific weights assigned based on their relative importance.

Methodology

The criteria analysis depicted in the table employs a weighted scoring model, wherein each criterion is assigned a factor of importance expressed as a percentage, collectively summing to 100%. In this instance, three distinct development strategies are evaluated: MicroPoise

ADR (supplier), in-house model development, and a combined in-house + ADR approach. Each strategy is rated on a predefined scale for each criterion. These ratings are multiplied by the respective importance factors to derive a weighted score for each criterion across all options. This method quantitatively measures each alternative's performance relative to the defined criteria.

Evaluation and Results

The evaluation results are quantified as *Value Benefit Sum* and *Percentage*, which represent the overall score and its proportion relative to a perfect score, respectively:

- **MicroPoise ADR** (supplier) achieved a score of 4,00 - translating to 39% of the total possible score.
- **In-house** model development received a score of 2,94 - or 29% of the possible score.
- **Combined In-house + ADR** attained a score of 3,33 - equating to 32% of the total possible score.

Ensuring Accuracy in Weights and Ratings

To ensure the accuracy of the weights and ratings, consultations were conducted with experts from Continental. These consultations aimed to accurately reflect true priorities and real-world considerations, thereby enhancing the reliability of the decision-making process.

This criteria analysis facilitates a structured and objective approach to comparing various strategic alternatives. By utilizing weighted scoring, decision-makers can prioritize each criterion according to its strategic relevance, aligning the decision-making process with organizational goals. This methodology is particularly useful in complex scenarios where balancing diverse factors is crucial, supporting a more rational and evidence-based decision-making approach.

Table 5 Criteria analysis

Criteria	Factor of importance	MicroPoise ADR (supplier)		In-house model development		Combined In-house + ADR	
		Rating	Result	Rating	Result	Rating	Result
1. Initial costs (first machine)	0%	4	0,00	3	0,00	3	0,00
2. Single supplier dependency	6%	0	0,00	5	0,28	2	0,11
3. Flexibility/Scalability/Further extensions possible	11%	3	0,33	5	0,56	5	0,56
4. Service/maintenance/support structures availability, experience needed to use software	17%	4	0,67	2	0,33	2	0,33
5. Operational costs	22%	4	0,89	3	0,67	2	0,44
6. Product scope/content/quality improvements	19%	5	0,97	2	0,39	5	0,97
7. Time to market	8%	4	0,33	2	0,17	3	0,25
8. Standard components used	3%	4	0,11	5	0,14	4	0,11
9. Level of automation	14%	5	0,69	3	0,42	4	0,56
Value benefit sum			4,00		2,94		3,33
Percentage	100%		39%		29%		32%

6.5 Roll-out plan of proposed solution

Chapter 6.5 provides a detailed strategic blueprint for the deployment of the Micropoise ADR solution, selected as the optimal strategy through comprehensive decision analysis discussed in previous chapters. This chapter elaborates on the phased implementation of the automated X-ray inspection system by Micropoise across the designated production facilities, focusing on the integration process, timeline, anticipated challenges, and mitigation strategies.

Introduction

Following a meticulous evaluation of various alternatives using criteria analysis and pairwise comparison, the Micropoise ADR solution emerged as the preferred choice due to its robust performance metrics, faster time-to-market, and lower dependency on extensive in-house development. This chapter outlines the practical steps and considerations necessary for the successful rollout of this solution, ensuring alignment with the operational goals and financial strategies of the organization.

Roll-out Objectives

The primary objectives of the rollout are to:

- **Minimize Disruption:** Ensure the integration of the Micropoise system with minimal disruption to existing operations.
- **Optimize Cost:** Manage the rollout cost-effectively, aligning with the budgetary constraints and financial forecasts outlined in previous analyses.

- **Achieve Timelines:** Meet strategic deployment milestones, ensuring quick time-to-market as highlighted as a key advantage of the Micropoise solution.
- **Ensure Quality and Compliance:** Maintain or enhance product quality and compliance with industry standards throughout the transition to the new system.

Roll-out Strategy

The rollout strategy is divided into several key phases, each designed to address specific aspects of the implementation process:

1. Preparation and Initial Setup:

- **Infrastructure Adjustments:** Modify existing conveyor systems and integrate necessary hardware components as required by the Micropoise system.
- **Software Installation and Configuration:** Deploy Micropoise software across targeted machines, ensuring compatibility with current IT infrastructure.

2. Training and Knowledge Transfer:

- **Operator Training:** Conduct comprehensive training sessions for operators (graders) to familiarize them with the new system functionalities and interface.
- **Technical Support Training:** Equip the technical support team with necessary troubleshooting skills and detailed knowledge of system maintenance.

3. Pilot Testing:

- **Initial Testing:** Implement the system in a controlled environment to test its functionality and integration with existing operations.
- **Feedback Loop:** Establish a feedback mechanism to collect insights from operators and technical staff, which will be crucial for adjusting the rollout process.

4. Full-Scale Implementation:

- **Gradual Scale-up:** Following successful pilot testing, gradually increase the number of machines and facilities running the Micropoise system.
- **Continuous Monitoring and Optimization:** Monitor system performance continuously, optimizing operational parameters to enhance efficiency and reduce downtimes.

5. Post-Implementation Review and Continuous Improvement:

- **Evaluation of System Performance:** Assess the overall impact of the Micropoise system on production efficiency, cost savings, and product quality.
- **Iterative Improvements:** Implement adjustments and software updates based on real-world performance and emerging technological advances.

Risk Management

Potential risks associated with the rollout include technical integration challenges, higher-than-anticipated operational costs, and resistance to change among the workforce. Each risk will be addressed through proactive strategies, such as conducting extensive compatibility tests, maintaining a transparent communication policy with all stakeholders, and providing incentives for early adoption and continuous engagement.

The rollout plan for the Micropoise ADR solution is designed to leverage the evaluated benefits while mitigating associated risks. By adhering to a structured and phased approach, the organization aims to ensure a smooth transition to a more efficient and cost-effective operational model, aligning with long-term strategic objectives and enhancing competitive advantage in the marketplace.

7 CONCLUSION AND OUTLOOK

The thesis presented an extensive examination of automated X-ray tire classification, a pivotal technology in enhancing the manufacturing process at Continental AG. The research systematically evaluated both existing solutions and an in-house artificial intelligence model, aiming to identify the most effective techniques for detecting and categorizing defects in tire manufacturing.

The thesis commenced by outlining the significance of advanced X-ray techniques in tire manufacturing, providing a backdrop for the research and setting the stage for a detailed exploration of existing technologies and the potential for AI-enhanced solutions. Chapter 2 reviewed the current landscape of X-ray tire inspection technologies. It detailed various approaches, focusing particularly on their application in industrial settings, and set the framework for developing a more sophisticated AI-driven model. Chapter 3 helped to define the research objectives and methodologies employed in the thesis. It laid out the comparative approach used to assess the effectiveness of different X-ray inspection systems, including commercial solutions and the in-house AI model. Chapter 4 described the development of an innovative AI model tailored to meet the specific needs of Continental AG's tire production. The model's capabilities were explored, emphasizing its potential to adapt to diverse manufacturing scenarios and its ability to improve over time through machine learning techniques. The analysis also examined how the newly optimized AI model stacked up against established commercial software. This comparison highlighted the strengths and weaknesses of each system, providing a clear picture of their operational and economic impacts. A comprehensive economic analysis of implementing each X-ray inspection system was also offered. This analysis helped quantify the potential return on investment and operational savings, aiding decision-makers in choosing the most cost-effective solution.

The thesis successfully demonstrated that the integration of AI technologies in X-ray tire inspection could significantly enhance defect detection accuracy and operational efficiency and help with fully automatic production. The Micropoise system, with its robust defect recognition capabilities, proved to be highly effective in a commercial setting. The in-house AI model, while requiring (and still requires) more initial development and integration effort,

showed potential for customization and flexibility, adapting well to the specific needs of the manufacturing process.

Looking forward, the thesis suggests that continual advancements in AI and machine learning will be crucial in further refining the capabilities of X-ray inspection systems. Future research should focus on developing AI models that can process a broader array of data inputs, improving both the accuracy and efficiency of tire inspections. Moreover, the economic analysis underscores the importance of evaluating the long-term cost implications of new technologies, ensuring that they provide not only technical but also financial benefits.

In conclusion, this thesis contributes valuable insights into the application of advanced technologies in tire manufacturing, paving the way for future innovations that could revolutionize quality control processes in the automotive industry. The ongoing evolution of AI promises to bring even greater efficiencies, heralding a new era of industrial automation.

Disclaimer: Artificial intelligence was predominantly used in this thesis as a tool for controlling and correcting the translation from Czech to English. Its application was intended to enhance the accuracy and consistency of the translated materials, ensuring that the interpretations remain true to the original meanings.

BIBLIOGRAPHY

- [1] Comet Yxlon, "Comet Yxlon," [Online]. Available: <https://yxlon.comet.tech/>. [Accessed 13 May 2024].
- [2] Continental, "History," [Online]. Available: <https://www.continental.com/en/company/history/>. [Accessed 13 May 2024].
- [3] Continental, "History," [Online]. Available: <https://www.continental-tires.com/ca/en/history/>. [Accessed 13 May 2024].
- [4] Continental, "Tire components," [Online]. Available: <https://www.continental-tires.com/products/b2c/tire-knowledge/tire-components/>. [Accessed 13 May 2024].
- [5] Continental, "Tire production," [Online]. Available: <https://www.continental-tires.com/products/b2c/tire-knowledge/tire-production/>. [Accessed 13 May 2024].
- [6] L. T. Nicole Laskowski, "What is artificial intelligence (AI)? Everything you need to know," [Online]. Available: <https://www.techtarget.com/searchenterpriseai/definition/AI-Artificial-Intelligence>. [Accessed 15 May 2024].
- [7] E. Glover, "Artificial Intelligence Definition," 2 April 2024. [Online]. Available: <https://builtin.com/artificial-intelligence>. [Accessed 15 May 2024].
- [8] R. Wolff, "5 Types of Classification Algorithms in Machine Learning," 26 August 2020. [Online]. Available: <https://monkeylearn.com/blog/classification-algorithms/>. [Accessed 15 May 2024].
- [9] F. Villegas, "Data-Driven AI: What It Is, Risks & Examples," [Online]. Available: <https://www.questionpro.com/blog/data-driven-ai/>. [Accessed 15 May 2024].
- [10] The Upwork Team, "How Is AI Used in Data Analysis? Examples and Applied Uses," 3 August 2023. [Online]. Available: <https://www.upwork.com/resources/ai-in-data-analysis>. [Accessed 15 May 2024].

- [11] SmartOne, 25 August 2023. [Online]. Available: <https://smartone.ai/blog/65-of-the-best-training-datasets-for-machine-learning/#best-datasets-repositories-for-machine-learning>. [Accessed 15 May 2024].
- [12] G. Boesch, "A Complete Guide to Image Classification in 2024," [Online]. Available: <https://viso.ai/computer-vision/image-classification/>. [Accessed 15 May 2024].
- [13] N. Pandey, "Lesson 2: Understanding Image Processing: Basics and Techniques in Computer Vision," 29 May 2023. [Online]. Available: <https://medium.com/@naveenpandey2706/lesson-2-understanding-image-processing-basics-and-techniques-in-computer-vision-c1d7c9763966>. [Accessed 16 May 2024].
- [14] H. Bandyopadhyay, "Autoencoders in Deep Learning: Tutorial & Use Cases [2023]," 4 June 2021. [Online]. Available: <https://www.v7labs.com/blog/autoencoders-guide>. [Accessed 16 May 2024].
- [15] M. Shivanandhan, "PyTorch vs TensorFlow – Which is Better for Deep Learning Projects?," 10 January 2024. [Online]. Available: <https://www.freecodecamp.org/news/pytorch-vs-tensorflow-for-deep-learning-projects/>. [Accessed 16 May 2024].
- [16] MicroPoise, "CTXS Plus," [Online]. Available: <https://www.micropoise.com/tire-industry/x-ray/ctxs-plus>. [Accessed 13 May 2024].
- [17] MicroPoise, "ADR Software - COLL-TECH X-RAY," [Online]. Available: <https://www.micropoise.com/tire-industry/x-ray/adr-software-colltech-xray>. [Accessed 13 May 2024].
- [18] CyXplus, "Tire Industry," [Online]. Available: <https://www.cyxplus.fr/products-services/tire-industry>. [Accessed 13 May 2024].
- [19] Alfamation S.p.A., "History of Innovation," [Online]. Available: <https://www.alfamationglobal.com/en/alfamation/history-of-innovation>. [Accessed 13 May 2024].
- [20] MEYER Europe s.r.o., "TIRES - X-RAY detection for tires," [Online]. Available: https://meyer-corp.eu/sorting/tire/#SEE_PRODUCT. [Accessed 13 May 2024].

- [21] D. Arend, "Entwicklung eines auf maschinellem Lernen basierenden Systems zur Analyse von Reifen-Röntgenbildern," in *Thesis*, Germany, Hochschule Hannover, 2021.

LIST OF ABBREVIATIONS

AI	Artificial Intelligence
ADR	Automatic Defect Recognition
PCR	Passenger Car Radial
TBR	Truck and Bus Radial
OTR	Off-The-Road
IT	Information Technology
PLC	Programmable Logic Controller
RFID	Radio Frequency Identification
SSIM	Structural Similarity Index Method
MTIS	Modular Tire Inspection System
CTXS	Coll-Tech X-ray System
px/mm	Pixel-to-Millimeter
CSV	Comma-Separated Values
CNN	Convolutional Neural Network

LIST OF FIGURES

Figure 1: X-ray machine from company Yxlon [1].....	9
Figure 2 Tire components which are described below [4].....	12
Figure 3 Quality ingredients for making essential compounds [5].....	15
Figure 4 Manufacturing of components [5].....	16
Figure 5 Building the tire [5]	17
Figure 6 Vulcanization [5].....	17
Figure 7 Example of Naive Bayes [8].....	25
Figure 8 Decision tree example [8].....	26
Figure 9 Image classification: The deep learning model returns classes along with the detection probability (confidence) [12].....	33
Figure 10 Concept of Convolutional Neural Networks (CNNs) [12].....	34
Figure 11 Convolutional encoder-decoder [14].....	38
Figure 12 Architecture of Autoencoders [14].....	38
Figure 13 Micropoise X-ray machine solution [16]	44
Figure 14 Bead disorder detected by ADR from Micropoise [17]	46
Figure 15 Findings in breaker by ADR from Micropoise [17].....	46
Figure 16 Body Ply findings with ADR from Micropoise [17].....	47
Figure 17 Ply automatically detected with ADR from Micropoise [17]	47
Figure 18: Air bubble detected by ADR from Micropoise [17]	48
Figure 19 Chafer automatic detection with ADR from Micropoise [17].....	48
Figure 20: RFID detected by ADR from Micropoise [17]	49
Figure 21 Ply-Turn-Up detected by ADR from Micropoise [17].....	49
Figure 22 X-ray inspection system MTIS [1].....	52
Figure 23 Tire manipulator for loading tires into MTIS system from conveying system [1]	52
Figure 24 UScan3 line detector and 4-spindle tire manipulator [1].....	53
Figure 25 Y.TireAXIS recognizes of the individual components of the tire and analyzes the structure, position, and dimensions. [1].....	54
Figure 26 CyXplus machine solution	56
Figure 27 Example from CyXscan software environment [18].....	57
Figure 28 Solution from company Alfamation [19]	58
Figure 29 Solution from company Mayer [20].....	58

Figure 30 Tire with asymmetric belt [21]	64
Figure 31 Image section with scaling factors of 1, ½, and ¼ [21].....	64
Figure 32 X-ray image with Splice marker.....	65
Figure 33: Normalization with the distribution of fitting the gray value [21]	68
Figure 34 Input image with defect (top), reconstructed output image (center), and difference image (bottom) [21]	72
Figure 35 Input image without defect (top), reconstructed output image (center), and difference image (bottom) [21]	73
Figure 36 Training and testing errors of the autoencoder architecture [21]	73
Figure 37 Matching between predicted and actual defect classes. [21].....	75
Figure 38 Comparing tested (actual tire) with template tire using small overlapping segments (not dimensionally accurate example).....	76
Figure 39 Comparing tested (actual tire) with template tire using small overlapping small pixel segments (not dimensionally accurate example)	77
Figure 40 Current X-ray image analyze process.....	94
Figure 41 Scenario - Fully automatic solution from the market.....	97
Figure 42 Scenario - Fully automatic in-house AI solution.....	99
Figure 43 Scenario - In-house solution with external software support	101
Figure 44 Cost-saving comparison between In-house solution and Micropoise SW solution thru all plants on the for all Continental plants roll-out	102

LIST OF TABLES

Table 1 Comparison of Trained Autoencoder Architectures [21]	72
Table 2 Comparing some of the chosen available SW solutions for X-ray inspection and their features	85
Table 3 Cost-benefit calculation for In-house and Micropoise fully automatic solution (without common costs) for all Continental plants roll-out	101
Table 4 Pairwise comparison	105
Table 5 Criteria analysis.....	107

APPENDICES

APPENDIX PI: CD